

Product Catalogue

直流减速电机/永磁直流电机/交流电机
DC gear motor / PMDC motor / AC motor



Working 办公环境 Conditions



企业简介

温州市正科电机有限公司是一家集科研、制造、销售于一体，有着 20 多年电机制造经验的现代化高新技术企业，公司青山绿水环绕，环境十分优美，毗邻有“世界地质公园”之称的中国著名旅游胜地——雁荡山风景区。甬台温高速公路、104 国道横贯全境，距温州机场只有半小时车程，交通十分便利。

正科电机公司是中国机电协会“一会二网”会员，技术力量雄厚，生产工艺先进，是目前国内生产永磁直流行星变速电机、齿轮减速电机、微电机、小模数渐开线圆柱齿轮等系列产品最专业、最齐全的厂家之一。公司全面贯彻 ISO9001:2000 质量管理体系要求，严格执行欧盟“CE”安全标准，并设立了专业的电机产品检测实验室，配备了当前国内最先进的耐压试验仪、测功机、示波器、电枢性能检验仪、老化试验台等全套现代化检测设备。每台减速电机的各项性能指标在出厂前都必须按照国家机电标准进行严格的检验测试，严把产品质量关，确保我们的客户买得称心，用得放心。

依靠社会各界的关爱和多年建立的市场信誉，公司产品在机械传动、稳定电源、家用电器、电动玩具、自动控制设备、医疗保健器材等诸多领域得到广泛使用和客户好评，并出口欧美、东南亚等国，深受国际市场青睐。

我们本着“品质至尊、开拓创新、诚信经营、客户至上”的经营宗旨与我们的合作伙伴互惠双赢、共同发展。

全体正科人恭候国内外客户的垂询和惠顾，期待与您携手并进、共创辉煌！

Brief Introduction

Wenzhou Zhengke Electromotor Co., Ltd is a modern high-tech enterprise merging research, manufacture, selling as one whole with a manufacturing history of above 20 years. The company has very beautiful scene of green hills and running streams, and it is near by the Chinese famous scenic spot Yandang Mountain, which is also called "The World Geology Park". Both Yongtaiwen speedway and 104 national highway run through the land, and it takes only half an hour to Wenzhou airport by bus with very convenient traffic.

Now Zhengke is one of the "one association, two networks" member of China Electric Machinery Association. With its strong technology ability and advanced production technics, it is one of the most professional manufacturers of China at present with full-scale products such as permanent magnetism DC planet gears shifting electric machinery, gear speed-down electric machinery, micro-electric machinery, small modulus column involute gear etc. The company fully carries out ISO9001-2000 quality management system and strictly performs CE safety standard of Europe Union, and it sets up professional exam laboratory of electric machinery products, equipped with full set of modern checkout equipment of national most advanced voltage withstand tester, dynamometer, oscillograph, armature performance check meter, aging test-bed etc. Every performance criteria of each speed-down electric machinery is strictly checked and tested according to national electric machinery standard before leaving factory. In order to ensure that our customer could buy the product satisfactorily and use it securely, we are quite strict with product quality.

With the care of all social sectors and its market credit standing, our products are widely used in various fields of machine transmission, stabilization power supply, family electrical equipment, dynamoelectric toy, autocontrol equipment, medical appliance, etc, getting good reputation from customers, and the products have been exported to countries in Occident, South-east Asia and so on and gotten favours in international market.

We adheres to management logos of quality first, pioneering and innovation, managing business with faith, customer is the king, and cooperate with our partners for mutual benefit and collaborative development.

Our Zhengke people warmly welcome customer's consultation and favour both at home and abroad, and expect creating refulgence together with you hand in hand!



Welcome to Zhengke Electromoto World!

欢迎进入正科电机世界! >>>

www.zhengke.cn

Production 生产车间 Workshop

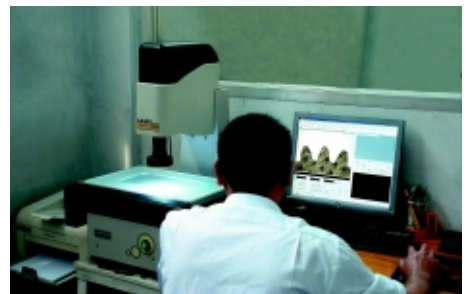

以质量为先，加大产品研究开发的投入
创造技术含量更高的产品

以此推动企业向更高更好的方向发展

Take the quality as the first, enlarge the investment volume for R&D of products

To create products with higher technology content

To drive the enterprise to a higher and better future



پرزسی، انتخاب و فرید آٹا این موٹور



高度的专业化 / 确保领先的服务质量
Specialization of Height / Ensure leading service quality

Qualification 资质证书 Certificate

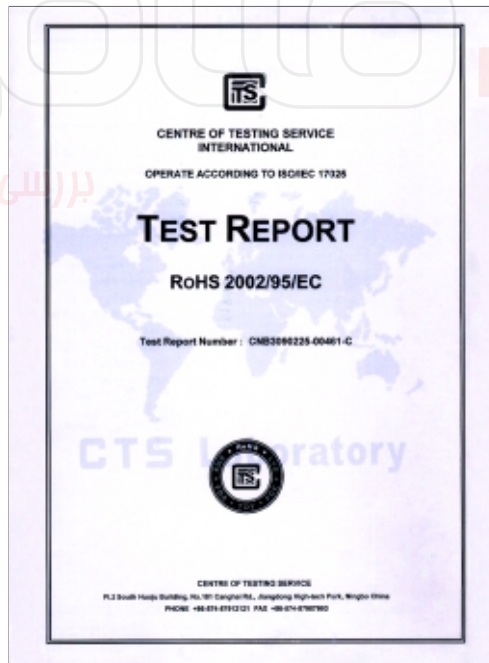

坚持稳定的产品质量，恪守产品制造的一丝不苟，
 在设计、在制造、在检测、在管理、在服务，
 每一个工序，完善的管理尽皆表露出 ISO9001:2000 的规范性、系统化和标准。
 凭借一流的开发、生产、检测、一流的质量保证体系和行业领先的生产工艺构建的核心竞争力，
 确保我们全力打造一流的产品品质。

Contents 产品目录

永磁直流行星减速电机 <i>PMDC Planetary Gear Motor</i>	1-7
永磁直流普通减速电机 <i>PMDC Spur Gear Motor</i>	8-48
稳压器专用减速电机 <i>Voltage Stabilizer Motor</i>	49-52
永磁直流电机 <i>PMDC Motor</i>	53-58
交流同步电机 <i>AC Synchro Motor</i>	59-60
交流可逆电机 <i>AC Reversible Motor</i>	61-67

型号及说明 Type & Explication

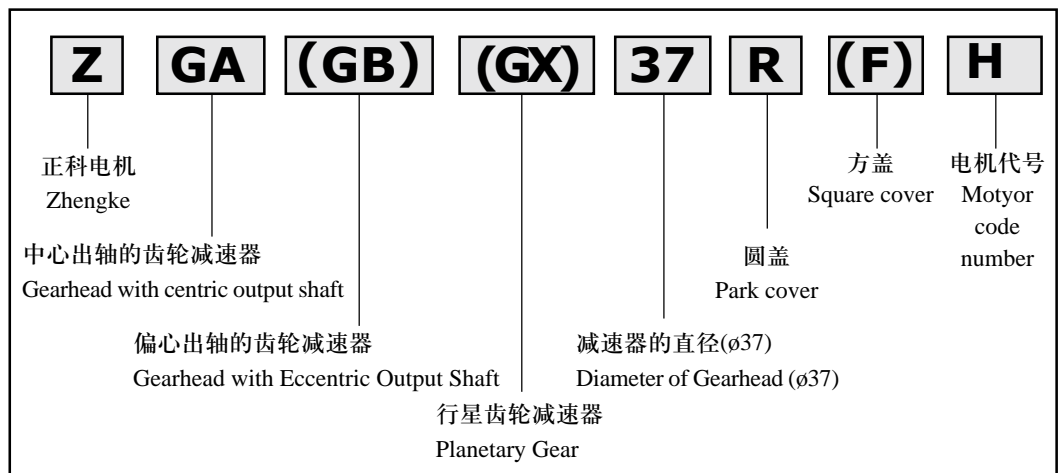

ZGX17RU

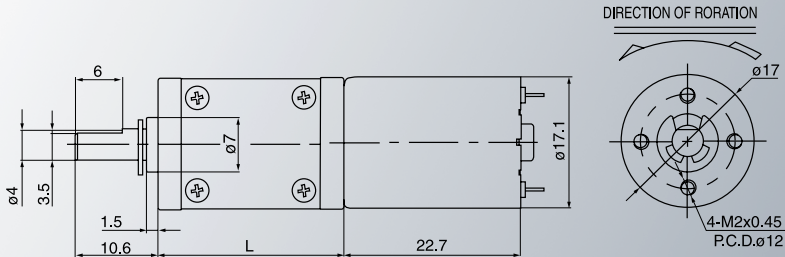

■技术参数 Technical Data

电压 Voltage(VDC)	6V	6V	6V	6V	6V	6V	12V	12V	12V	12V	12V
马达型号 Motor Model	64U	64U	64U	64U	64U	64U	128U	128U	128U	128U	128U
减速比 Reduction Ratio	1/23	1/64	1/90	1/107	1/256	1/256	1/23	1/64	1/90	1/107	1/256
齿轮箱长度 Gearbox Length(mm)	25	30	30	30	34	34	25	30	30	30	34
空载转速 No-Load Speed(Rpm)	255	90	64	54	23	23	510	180	128	108	45
额定转速 Rated Speed(Rpm)	178	63	45	38	16	16	357	126	90	75	32
额定力矩 Rated Torque(Kg.cm)	0.11	0.30	0.44	0.50	1.13	1.13	0.14	0.36	0.50	0.60	1.28
额定电流 Rated Current(Amp)	0.24	0.24	0.24	0.24	0.24	0.24	0.22	0.22	0.22	0.22	0.22
短时间最大负载 Max.Momentary Torque(Kg.cm)	0.14	0.38	0.55	0.63	1.41	1.41	0.18	0.45	0.63	0.75	1.61

ZGX17R-050

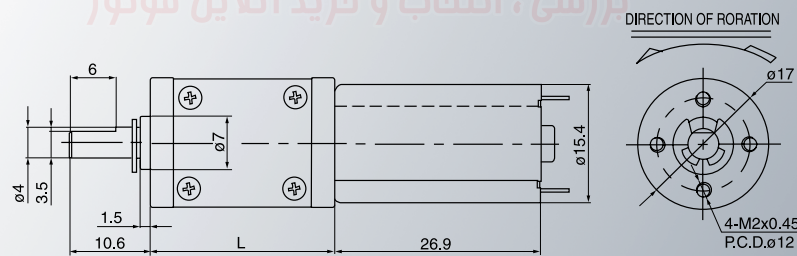

■技术参数 Technical Data

电压 Voltage(VDC)	6V	6V	6V	6V	6V	6V	12V	12V	12V	12V	12V
马达型号 Motor Model	85-050	82-050	82-050	82-050	82-050	82-050	165-050	165-050	165-050	165-050	165-050
减速比 Reduction Ratio	1/23	1/64	1/90	1/107	1/256	1/256	1/23	1/65	1/90	1/107	1/256
齿轮箱长度 Gearbox Length(mm)	25	30	30	30	34	34	25	30	30	30	34
空载转速 No-Load Speed(Rpm)	322	116	82	70	30	30	657	232	165	139	58
额定转速 Rated Speed(Rpm)	193	69	49	42	18	18	460	162	116	97	41
额定力矩 Rated Torque(Kg.cm)	0.16	0.44	0.56	0.65	1.37	1.37	0.30	0.81	1.13	1.35	3.07
额定电流 Rated Current(Amp)	0.31	0.31	0.31	0.31	0.31	0.31	0.38	0.38	0.38	0.38	0.38
短时间最大负载 Max.Momentary Torque(Kg.cm)	0.40	1.10	1.40	1.63	3.43	3.43	0.38	1.01	1.42	1.69	3.83

★备注: 1. 若需要其它规格, 敬请来电联系 2. 如若我司以上规格产生变动, 请恕不再另行通知。

Remark: 1.If any specifications else you required are not listed above, Please contact us 2.The specifications are subject to change without notice.

ZGX22RW

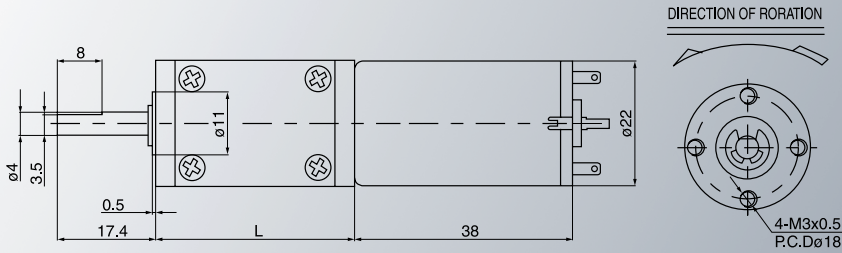

■技术参数 Technical Data

电压 Voltage(VDC)	12V	12V	12V	12V	12V	12V	12V	12V	12V	12V
马达型号 Motor Model	60W	60W	60W	60W	60W	60W	60W	60W	60W	60W
减速比 Reduction Ratio	1/16	1/29	1/43	1/74	1/90	1/107	1/150	1/256	1/509	
齿轮箱长度 Gearbox Length(mm)	27	27	27	31	31	31	31	35	35	
空载转速 No-Load Speed(Rpm)	375	206	140	81	67	56	40	23	12	
额定转速 Rated Speed(Rpm)	285	156	106	61	51	42	30	17	9	
额定力矩 Rated Torque(Kg.cm)	0.74	1.36	1.99	3.12	3.73	4.53	6.34	10.08	19.04	
额定电流 Rated Current(Amp)	0.26	0.26	0.26	0.26	0.26	0.26	0.26	0.26	0.26	
短时间最大负载 Max.Momentary Torque(Kg.cm)	0.93	1.70	2.49	3.90	4.66	5.66	7.93	12.60	23.80	

ZGX24RP

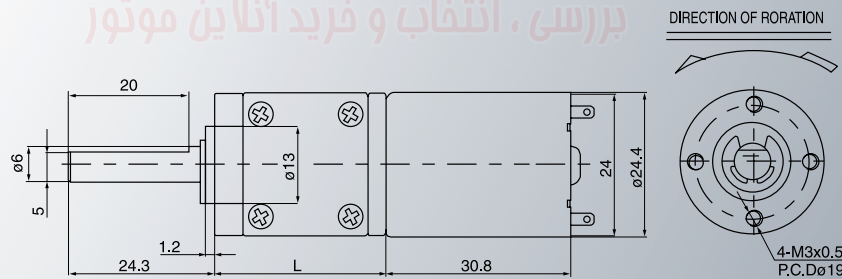

■技术参数 Technical Data

电压 Voltage(VDC)	12V	12V	12V	12V	12V	24V	24V	24V	24V	24V
马达型号 Motor Model	56P	56P	56P	56P	56P	47P	47P	47P	47P	47P
减速比 Reduction Ratio	1/38	1/69	1/139	1/221	1/384	1/38	1/69	1/139	1/221	1/384
齿轮箱长度 Gearbox Length(mm)	33	33	33	37	37	33	33	33	37	37
空载转速 No-Load Speed(Rpm)	148	81	40	25	15	125	68	34	21	12
额定转速 Rated Speed(Rpm)	112	61	30	19	11	95	52	26	16	9
额定力矩 Rated Torque(Kg.cm)	1.19	2.18	4.45	6.32	10.92	0.76	1.39	2.80	4.23	7.35
额定电流 Rated Current(Amp)	0.21	0.21	0.21	0.21	0.21	0.10	0.10	0.10	0.10	0.10
短时间最大负载 Max.Momentary Torque(Kg.cm)	1.49	2.73	5.56	7.90	13.65	0.95	1.74	3.50	5.29	9.19

★备注: 1. 若需要其它规格, 敬请来电联系 2. 如若我司以上规格产生变动, 请恕不再另行通知。

Remark: 1.If any specifications else you required are not listed above, Please contact us 2.The specifications are subject to change without notice.

ZGX28RO

RS-385-12VDC/5000RPM

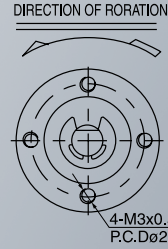
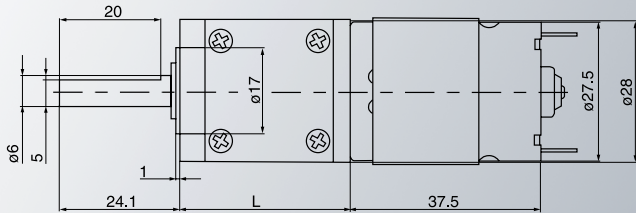

■技术参数 Technical Data

电压 Voltage(VDC)	12V	12V	12V	12V	12V	24V	24V	24V	24V	24V
马达型号 Motor Model	500	500	500	500	500	500	500	500	500	500
减速比 Reduction Ratio	1/22	1/38	1/83	1/139	1/384	1/22	1/38	1/83	1/139	1/384
齿轮箱长度 Gearbox Length(mm)	29	33	33	33	37	29	33	33	33	37
空载转速 No-Load Speed(Rpm)	233	133	60	36	13	233	133	60	36	13
额定转速 Rated Speed(Rpm)	177	101	46	27	10	177	101	46	27	10
额定力矩 Rated Torque(Kg.cm)	0.98	1.56	3.48	5.79	14.23	1.22	2.14	4.70	7.89	21.79
额定电流 Rated Current(Amp)	0.63	0.63	0.63	0.63	0.63	0.31	0.31	0.31	0.31	0.31
短时间最大负载 Max.Momentary Torque(Kg.cm)	1.22	1.95	4.35	7.24	17.79	1.53	2.67	5.88	9.86	27.24

ZGX28R-395

بررسی، انتخاب و خرید آنلاین موتور

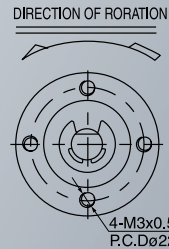
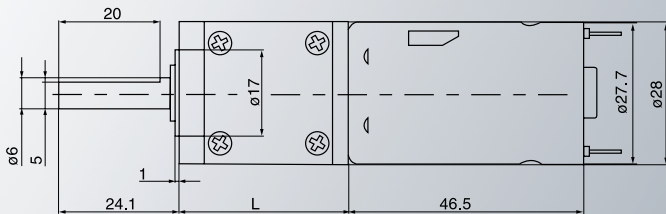

■技术参数 Technical Data

电压 Voltage(VDC)	12V	12V	12V	12V	12V	24V	24V	24V	24V	24V
马达型号 Motor Model	75-395	75-395	75-395	75-395	75-395	75-395	75-395	75-395	75-395	75-395
减速比 Reduction Ratio	1/50	1/83	1/139	1/221	1/384	1/38	1/50	1/83	1/139	1/221
齿轮箱长度 Gearbox Length(mm)	33	33	33	37	37	33	33	33	33	37
空载转速 No-Load Speed(Rpm)	150	90	54	34	20	197	150	90	54	34
额定转速 Rated Speed(Rpm)	114	68	41	26	15	150	114	69	41	26
额定力矩 Rated Torque(Kg.cm)	3.29	5.52	9.15	13.12	22.75	6.19	8.15	13.54	22.70	32.49
额定电流 Rated Current(Amp)	1.20	1.20	1.20	1.20	1.20	0.73	0.73	0.73	0.73	0.73
短时间最大负载 Max.Momentary Torque(Kg.cm)	4.11	6.90	11.44	16.40	28.44	7.74	10.19	16.92	28.38	40.61

★备注: 1. 若需要其它规格, 敬请来电联系 2. 如若我司以上规格产生变动, 请恕不再另行通知。

Remark: 1.If any specifications else you required are not listed above, Please contact us 2.The specifications are subject to change without notice.

ZGX32R-395

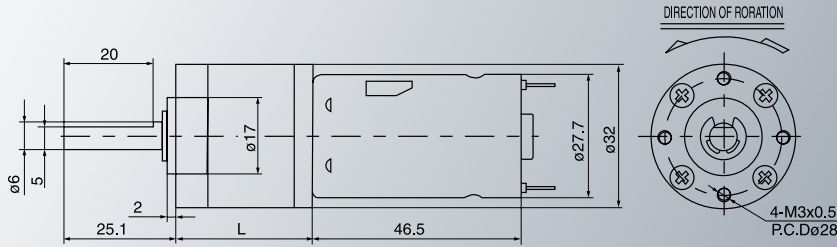

■技术参数 Technical Data

电压 Voltage(VDC)	12V	12V	12V	12V	12V	24V	24V	24V	24V	24V
马达型号 Motor Model	75-395	75-395	75-395	75-395	75-395	75-395	75-395	75-395	75-395	75-395
减速比 Reduction Ratio	1/50	1/83	1/100	1/139	1/221	1/50	1/83	1/100	1/139	1/221
齿轮箱长度 Gearbox Length(mm)	30	30	30	34	34	30	30	30	34	34
空载转速 No-Load Speed(Rpm)	150	90	75	54	34	150	90	75	54	34
额定转速 Rated Speed(Rpm)	114	69	57	41	26	114	69	57	41	26
额定力矩 Rated Torque(Kg.cm)	3.29	5.46	6.58	9.15	14.54	8.14	13.51	16.28	22.63	32.38
额定电流 Rated Current(Amp)	1.20	1.20	1.20	1.20	1.20	0.73	0.73	0.73	0.73	0.73
短时间最大负载 Max.Momentary Torque(Kg.cm)	4.94	8.19	9.87	13.72	21.81	12.21	20.27	24.42	33.94	48.57

ZGX36RH

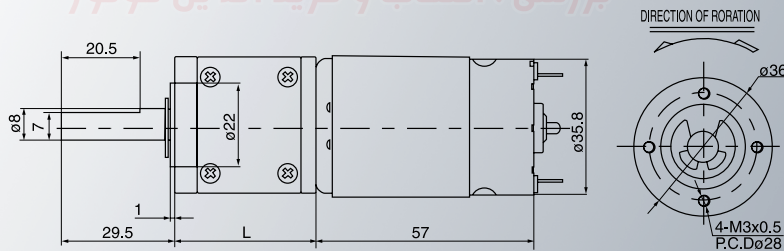

■技术参数 Technical Data

电压 Voltage(VDC)	12V	12V	12V	12V	12V	24V	24V	24V	24V	24V
马达型号 Motor Model	53H	53H	53H	53H	53H	60H	60H	60H	60H	60H
减速比 Reduction Ratio	1/44	1/67	1/100	1/149	1/175	1/44	1/67	1/100	1/149	1/175
齿轮箱长度 Gearbox Length(mm)	38	44	44	44	51	38	44	44	44	51
空载转速 No-Load Speed(Rpm)	122	80	53	36	30	138	90	60	40	34
额定转速 Rated Speed(Rpm)	92	60	40	27	23	105	68	46	31	26
额定力矩 Rated Torque(Kg.cm)	6.30	9.14	13.67	20.45	22.82	9.20	14.05	21.02	31.44	36.93
额定电流 Rated Current(Amp)	1.58	1.58	1.58	1.58	1.58	0.95	0.95	0.95	0.95	0.95
短时间最大负载 Max.Momentary Torque(Kg.cm)	9.45	13.71	20.51	30.68	34.23	13.80	21.08	31.52	47.16	55.39

★备注: 1. 若需要其它规格, 敬请来电联系 2. 如若我司以上规格产生变动, 请恕不再另行通知。

Remark: 1. If any specifications else you required are not listed above, Please contact us 2. The specifications are subject to change without notice.

ZGX36R-590

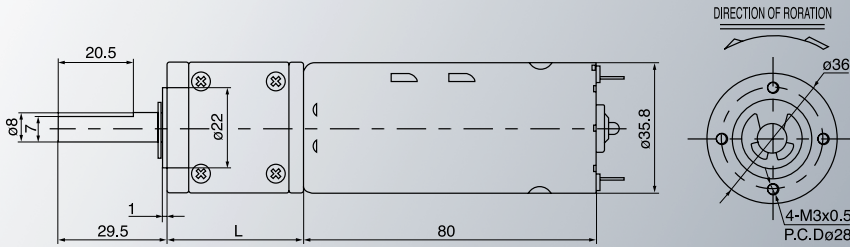

■技术参数 Technical Data

电压 Voltage(VDC)	12V	12V	12V	12V	12V	24V	24V	24V
马达型号 Motor Model	45-590	45-590	45-590	45-590	45-590	45-590	45-590	45-590
减速比 Reduction Ratio	1/44	1/67	1/100	1/149	1/175	1/44	1/67	1/100
齿轮箱长度 Gearbox Length(mm)	38	44	44	44	51	38	44	44
空载转速 No-Load Speed(Rpm)	103	68	45	30	26	103	68	45
额定转速 Rated Speed(Rpm)	78	51	34	23	20	78	51	34
额定力矩 Rated Torque(Kg.cm)	15.00	21.77	32.55	48.70	54.34	15.00	20.62	30.84
额定电流 Rated Current(Amp)	1.95	1.95	1.95	1.95	1.95	0.98	0.98	0.98
短时间最大负载 Max.Momentary Torque(Kg.cm)	22.50	32.65	48.83	73.05	81.50	22.50	30.93	46.26

ZGX38REE

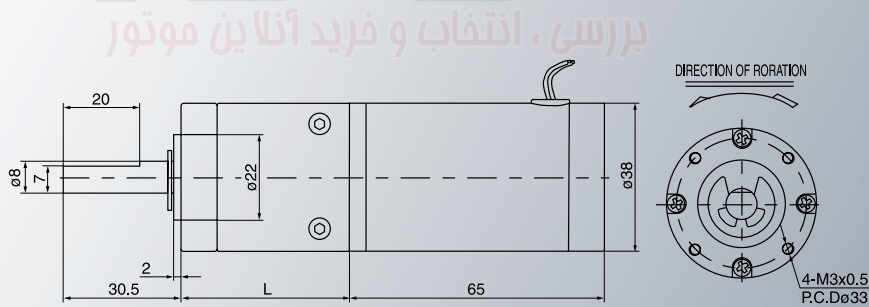

■技术参数 Technical Data

电压 Voltage(VDC)	12V	12V	12V	12V	12V	24V	24V	24V	24V	24V
马达型号 Motor Model	50EE	50EE	50EE	50EE	50EE	55EE	55EE	55EE	55EE	55EE
减速比 Reduction Ratio	1/30	1/44	1/72	1/100	1/149	1/30	1/44	1/72	1/100	1/149
齿轮箱长度 Gearbox Length(mm)	37	37	43	43	43	37	37	43	43	43
空载转速 No-Load Speed(Rpm)	168	115	70	50	34	185	126	77	55	37
额定转速 Rated Speed(Rpm)	128	87	53	38	26	141	96	58	42	28
额定力矩 Rated Torque(Kg.cm)	5.28	7.75	12.13	16.82	25.16	8.30	12.18	20.07	27.83	41.64
额定电流 Rated Current(Amp)	1.70	1.70	1.70	1.70	1.70	1.20	1.20	1.20	1.20	1.20
短时间最大负载 Max.Momentary Torque(Kg.cm)	6.60	9.69	15.16	21.03	31.46	10.38	15.23	25.08	34.79	52.05

★备注: 1. 若需要其它规格, 敬请来电联系 2. 如若我司以上规格产生变动, 请恕不再另行通知。

Remark: 1.If any specifications else you required are not listed above, Please contact us 2.The specifications are subject to change without notice.

ZGX45RGG

ZYTD45SRZ-12VDC/4000RPM

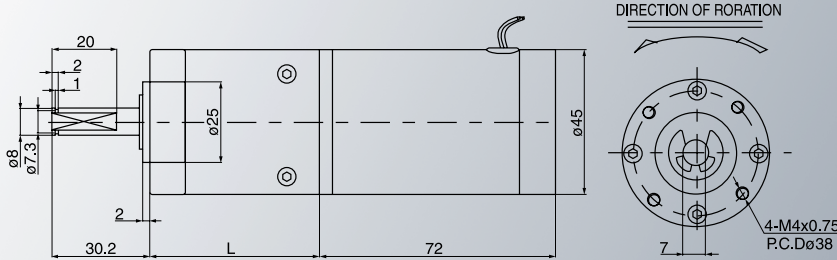

■技术参数 Technical Data

电压 Voltage(VDC)	12V	12V	12V	12V	12V	24V	24V	24V	24V	24V
马达型号 Motor Model	40GG	40GG	40GG	40GG	40GG	40GG	40GG	40GG	40GG	40GG
减速比 Reduction Ratio	1/27	1/33	1/46	1/94	1/192	1/27	1/33	1/46	1/94	1/192
齿轮箱长度 Gearbox Length(mm)	44	44	44	52	52	44	44	44	52	52
空载转速 No-Load Speed(Rpm)	149	121	87	43	21	149	121	87	43	21
额定转速 Rated Speed(Rpm)	113	92	66	32	16	113	92	66	32	16
额定力矩 Rated Torque(Kg.cm)	8.63	10.63	14.81	28.76	58.74	15.53	19.12	26.66	46.30	85.11
额定电流 Rated Current(Amp)	2.00	2.00	2.00	2.00	2.00	1.50	1.50	1.50	1.50	1.50
短时间最大负载 Max.Momentary Torque(Kg.cm)	10.79	13.28	18.52	35.94	73.42	19.41	23.90	33.32	57.88	106.39

ZGX50RHH

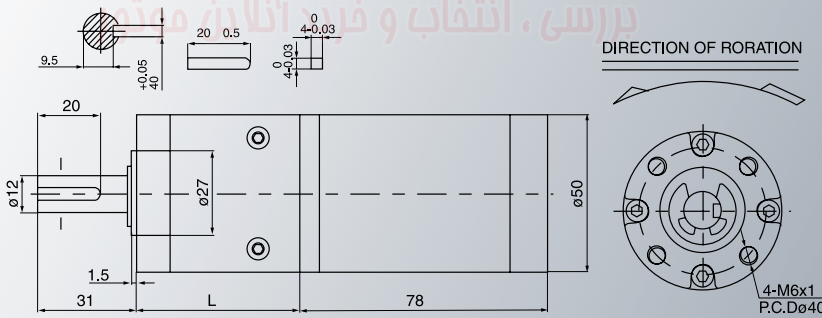

■技术参数 Technical Data

电压 Voltage(VDC)	12V	12V	12V	12V	12V	24V	24V	24V	24V	24V
马达型号 Motor Model	50HH	50HH	50HH	50HH	50HH	60HH	60HH	60HH	60HH	60HH
减速比 Reduction Ratio	1/22	1/32	1/78	1/122	1/166	1/22	1/32	1/78	1/122	1/166
齿轮箱长度 Gearbox Length(mm)	43	43	53	53	53	43	43	53	53	53
空载转速 No-Load Speed(Rpm)	227	155	64	41	30	273	186	77	49	36
额定转速 Rated Speed(Rpm)	173	118	49	31	23	207	141	59	37	27
额定力矩 Rated Torque(Kg.cm)	6.08	8.93	20.43	32.06	43.56	14.24	20.91	45.32	71.13	96.64
额定电流 Rated Current(Amp)	3.00	3.00	3.00	3.00	3.00	4.20	4.20	4.20	4.20	4.20
短时间最大负载 Max.Momentary Torque(Kg.cm)	7.60	11.16	25.53	40.07	54.45	17.80	26.13	56.65	88.91	120.81

★备注: 1. 若需要其它规格, 敬请来电联系 2. 如若我司以上规格产生变动, 请恕不再另行通知。

Remark: 1.If any specifications else you required are not listed above, Please contact us 2.The specifications are subject to change without notice.

ZGX60RMM

ZYTD60SRZ-12VDC/5000RPM

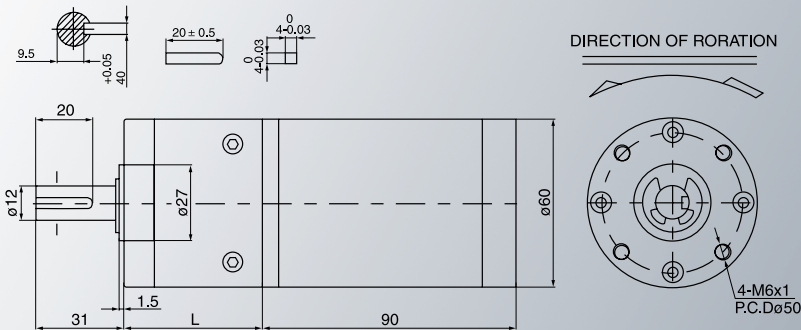

■技术参数 Technical Data

电压 Voltage(VDC)	12V	12V	12V	12V	12V	24V	24V	24V	24V	24V
马达型号 Motor Model	60MM	60MM	60MM	60MM	60MM	50MM-1	50MM-1	50MM-1	50MM-1	50MM-1
减速比 Reduction Ratio	28	41	50	109	134	134	28	50	109	134
齿轮箱长度 Gearbox Length(mm)	43	43	43	53	53	53	43	43	53	53
空载转速 No-Load Speed(Rpm)	181	122	100	46	37	37	181	100	46	37
额定转速 Rated Speed(Rpm)	137	93	76	35	28	28	137	76	35	28
额定力矩 Rated Torque(Kg.cm)	21.35	31.60	38.69	75.26	93.09	93.09	31.30	56.72	110.34	136.48
额定电流 Rated Current(Amp)	6.00	6.00	6.00	6.00	6.00	6.00	3.50	3.50	3.50	3.50
短时间最大负载 Max.Momentary Torque(Kg.cm)	26.69	39.50	48.37	94.08	116.37	116.37	39.13	70.91	137.93	170.60

بررسی، انتخاب و فرید آنلاین موتور

★备注: 1.若需要其它规格, 敬请来电联系 2.如若我司以上规格产生变动, 请恕不再另行通知。

Remark: 1.If any specifications else you required are not listed above, Please contact us 2.The specifications are subject to change without notice.

ZGA12FT

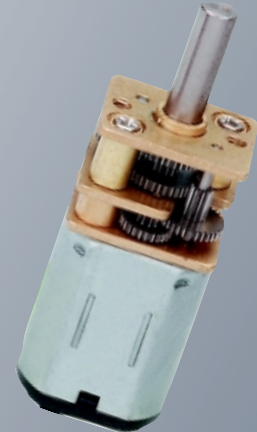
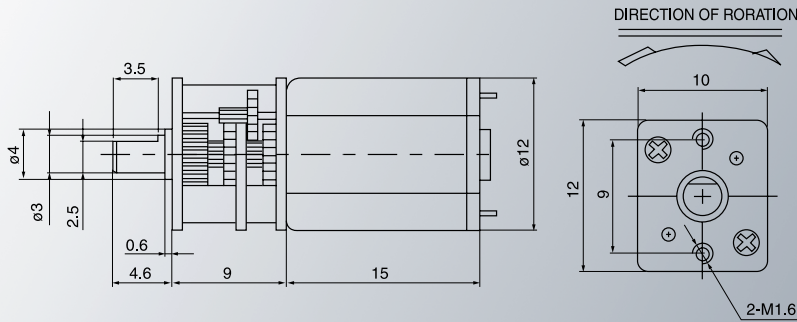

■技术参数 Technical Data

电压 Voltage(VDC)	3VDC	3VDC	4.5VDC	4.5VDC	5VDC	5VDC	6VDC	6VDC
减速比 Reduction Ratio	1/36	1/30	1/298	1/210	1/298	1/50	1/298	1/100
空载转速 No-Load Speed(Rpm)	85	400	45	75	62	240	35	120
额定转速 Rated Speed(Rpm)	80	350	38	54	56	210	30	100
额定力矩 Rated Torque(Kg.cm)	0.30	0.18	1.70	1.50	1.80	0.30	1.70	0.60
额定电流 Rated Current(Amp)	0.13	0.15	0.18	0.11	0.13	0.09	0.14	0.21

ZGA17RT

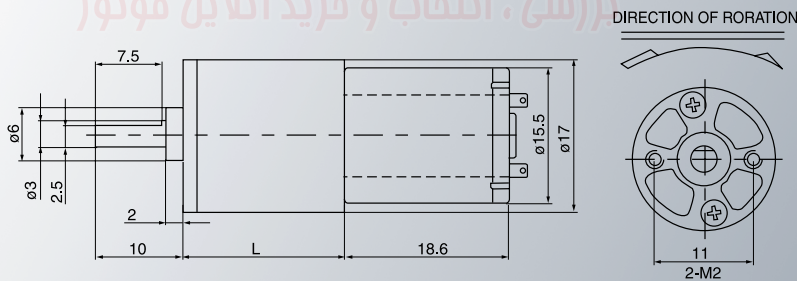

■技术参数 Technical Data

电压 Voltage(VDC)	3V	3V	3V	3V	3V	3V	3V	3V	3V
马达型号 Motor Model	91T	91T	91T	91T	91T	140T	140T	140T	140T
减速比 Reduction Ratio	1/19	1/40	1/83	1/175	1/365	1/19	1/40	1/83	1/175
齿轮箱长度 Gearbox Length(mm)	17	17	18	20	22	17	17	18	20
空载转速 No-Load Speed(Rpm)	479	228	110	52	25	737	350	169	80
额定转速 Rated Speed(Rpm)	335	159	77	36	17	516	245	118	56
额定力矩 Rated Torque(Kg.cm)	0.03	0.06	0.13	0.28	0.58	0.05	0.11	0.22	0.46
额定电流 Rated Current(Amp)	0.28	0.28	0.28	0.28	0.28	0.28	0.28	0.28	0.28
短时间最大负载 Max.Momentary Torque(Kg.cm)	0.05	0.09	0.20	0.41	0.86	0.08	0.16	0.33	0.69

★备注: 1. 若需要其它规格, 敬请来电联系 2. 如若我司以上规格产生变动, 请恕不再另行通知。

Remark: 1.If any specifications else you required are not listed above, Please contact us 2.The specifications are subject to change without notice.

ZGA17RU

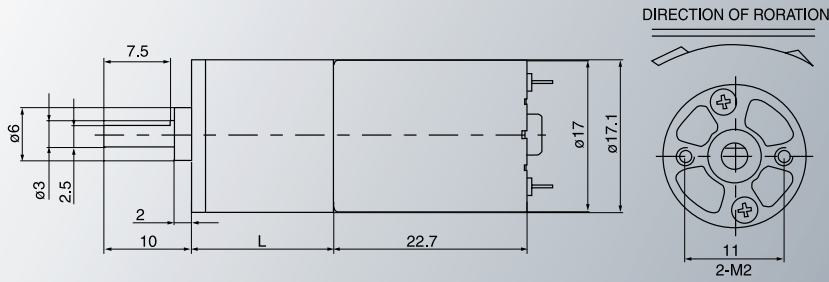

■技术参数 Technical Data

电压 Voltage(VDC)	6V	6V	6V	6V	6V	12V	12V	12V	12V	12V
马达型号 Motor Model	46U	46U	46U	46U	46U	56U	56U	56U	56U	56U
减速比 Reduction Ratio	1/19	1/40	1/84	1/175	1/365	1/19	1/40	1/84	1/175	1/365
齿轮箱长度 Gearbox Length(mm)	17	17	18	20	22	17	17	18	20	22
空载转速 No-Load Speed(Rpm)	242	115	55	26	13	295	140	67	32	15
额定转速 Rated Speed(Rpm)	184	87	42	20	10	224	106	51	24	12
额定力矩 Rated Torque(Kg.cm)	0.03	0.06	0.13	0.28	0.58	0.02	0.05	0.11	0.2	0.47
额定电流 Rated Current(Amp)	0.10	0.10	0.10	0.10	0.10	0.04	0.04	0.04	0.04	0.04
短时间最大负载 Max.Momentary Torque(Kg.cm)	0.04	0.08	0.17	0.35	0.72	0.03	0.06	0.14	0.28	0.59

ZGA20RS

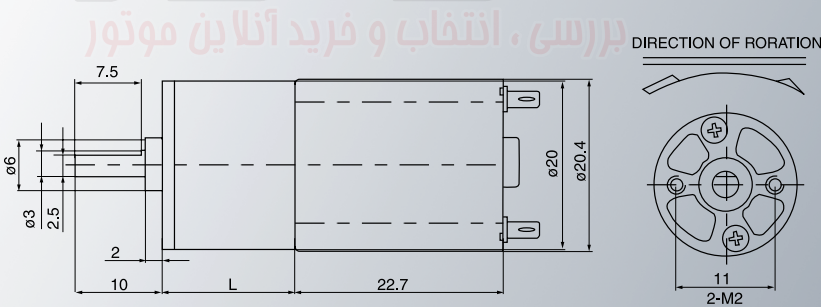

■技术参数 Technical Data

电压 Voltage(VDC)	6V	6V	6V	6V	6V	12V	12V	12V	12V	12V
马达型号 Motor Model	41S	41S	41S	41S	41S	55S	55S	55S	55S	55S
减速比 Reduction Ratio	1/14	1/33	1/80	1/191	1/459	1/14	1/33	1/80	1/191	459
齿轮箱长度 Gearbox Length(mm)	17	17	17	18	20	17	17	17	18	20
空载转速 No-Load Speed(Rpm)	297	124	52	21	9	398	166	69	28	12
额定转速 Rated Speed(Rpm)	208	87	36	15	6	302	126	52	21	9
额定力矩 Rated Torque(Kg.cm)	0.06	0.17	0.35	0.83	2.00	0.05	0.11	0.28	0.63	1.32
额定电流 Rated Current(Amp)	0.18	0.18	0.18	0.18	0.18	0.12	0.12	0.12	0.12	0.12
短时间最大负载 Max.Momentary Torque(Kg.cm)	0.09	0.22	0.52	1.25	2.99	0.06	0.137	0.38	0.782	1.645

★备注: 1. 若需要其它规格, 敬请来电联系 2. 如若我司以上规格产生变动, 请恕不再另行通知。

Remark: 1.If any specifications else you required are not listed above, Please contact us 2.The specifications are subject to change without notice.

ZGA25RQ

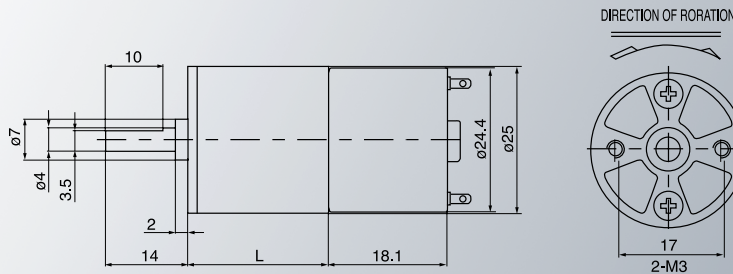

■技术参数 Technical Data

电压 Voltage(VDC)	3V	3V	3V	3V	3V	6V	6V	6V	6V	6V
马达型号 Motor Model	40Q	40Q	40Q	40Q	40Q	52Q	52Q	52Q	52Q	52Q
减速比 Reduction Ratio	13	38	83	156	253	13	38	83	156	253
齿轮箱长度 Gearbox Length(mm)	19	19	22	24	24	19	19	22	24	24
空载转速 No-Load Speed(Rpm)	320	105	48	26	26	400	131	60	32	20
额定转速 Rated Speed(Rpm)	224	74	34	18	18	280	92	42	22	14
额定力矩 Rated Torque(Kg.cm)	0.04	0.12	0.27	0.50	0.50	0.06	0.18	0.39	0.73	1.16
额定电流 Rated Current(Amp)	0.12	0.12	0.12	0.12	0.12	0.06	0.06	0.06	0.06	0.06
短时间最大负载 Max.Momentary Torque(Kg.cm)	0.06	0.18	0.40	0.75	0.75	0.09	0.27	0.58	1.09	1.74

ZGB25RQ

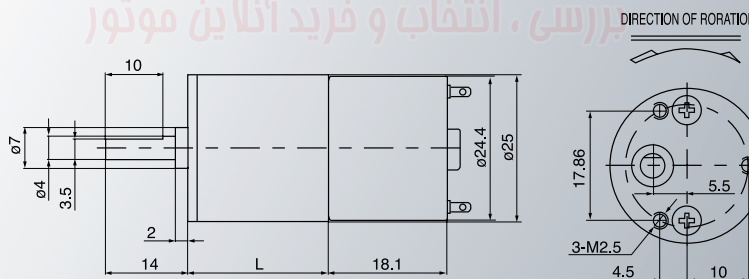

■技术参数 Technical Data

电压 Voltage(VDC)	3V	3V	3V	3V	3V	6V	6V	6V	6V	6V
马达型号 Motor Model	40Q	40Q	40Q	40Q	40Q	52Q	52Q	52Q	52Q	52Q
减速比 Reduction Ratio	1/13	1/28	1/83	1/184	1/344	1/13	1/28	1/83	1/184	1/344
齿轮箱长度 Gearbox Length(mm)	19	19	22	24	26	19	19	22	24	26
空载转速 No-Load Speed(Rpm)	308	143	48	22	12	400	186	63	28	15
额定转速 Rated Speed(Rpm)	215	100	34	15	8	280	130	44	20	11
额定力矩 Rated Torque(Kg.cm)	0.04	0.09	0.26	0.57	1.06	0.06	0.13	0.38	0.85	1.59
额定电流 Rated Current(Amp)	0.12	0.12	0.12	0.12	0.12	0.06	0.06	0.06	0.06	0.06
短时间最大负载 Max.Momentary Torque(Kg.cm)	0.06	0.13	0.38	0.85	1.59	0.09	0.19	0.57	1.27	2.38

★备注: 1. 若需要其它规格, 敬请来电联系 2. 如若我司以上规格产生变动, 请恕不再另行通知。

Remark: 1. If any specifications else you required are not listed above, Please contact us 2. The specifications are subject to change without notice.

ZGA25RP

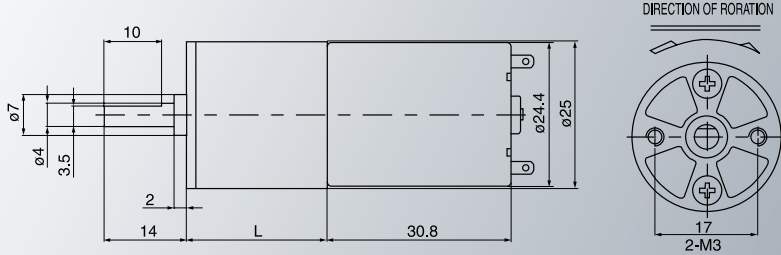

■技术参数 Technical Data

电压 Voltage(VDC)	12V	12V	12V	12V	12V	24V	24V	24V	24V	24V
马达型号 Motor Model	56P	56P	56P	56P	56P	47P	47P	47P	47P	47P
减速比 Reduction Ratio	1/13	1/38	1/98	1/156	1/344	1/13	1/38	1/98	1/156	1/344
齿轮箱长度 Gearbox Length(mm)	19	19	22	24	27	19	19	22	24	27
空载转速 No-Load Speed(Rpm)	448	147	57	36	16	376	124	48	30	14
额定转速 Rated Speed(Rpm)	340	112	43	27	12	286	94	36	23	10
额定力矩 Rated Torque(Kg.cm)	0.24	0.73	1.79	2.70	5.66	0.27	0.82	2.01	3.04	6.37
额定电流 Rated Current(Amp)	0.20	0.20	0.20	0.20	0.20	0.10	0.10	0.10	0.10	0.10
短时间最大负载 Max.Momentary Torque(Kg.cm)	0.36	1.09	2.68	4.05	8.49	0.41	1.23	3.02	4.56	9.56

ZGB25RP

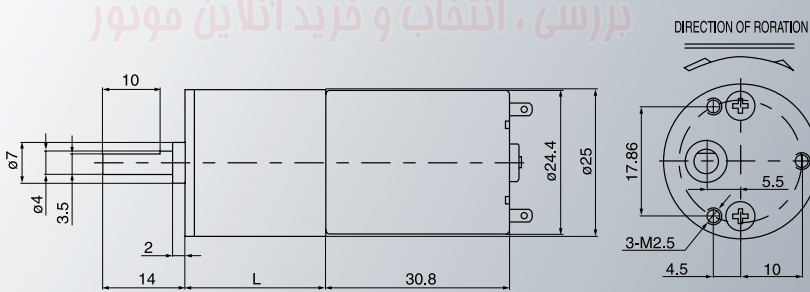

■技术参数 Technical Data

电压 Voltage(VDC)	12V	12V	12V	12V	24V	24V	24V	24V	24V	24V
马达型号 Motor Model	56P	56P	56P	56P	47P	47P	47P	47P	47P	47P
减速比 Reduction Ratio	1/23	1/83	1/184	1/253	1/11	1/23	1/83	1/184	1/184	1/253
齿轮箱长度 Gearbox Length(mm)	19	22	24	26	19	19	22	24	24	26
空载转速 No-Load Speed(Rpm)	243	67	30	22	427	204	57	26	26	19
额定转速 Rated Speed(Rpm)	185	51	23	17	325	155	43	19	19	14
额定力矩 Rated Torque(Kg.cm)	0.44	1.51	3.17	4.14	0.24	0.50	1.72	3.62	3.62	4.73
额定电流 Rated Current(Amp)	0.20	0.20	0.20	0.20	0.10	0.10	0.10	0.10	0.10	0.10
短时间最大负载 Max.Momentary Torque(Kg.cm)	0.66	2.26	4.76	6.21	0.36	0.75	2.58	5.43	5.43	7.10

★备注: 1.若需要其它规格, 敬请来电联系 2.如若我司以上规格产生变动, 请恕不再另行通知。

Remark: 1.If any specifications else you required are not listed above, Please contact us 2.The specifications are subject to change without notice.

ZGA28RQ

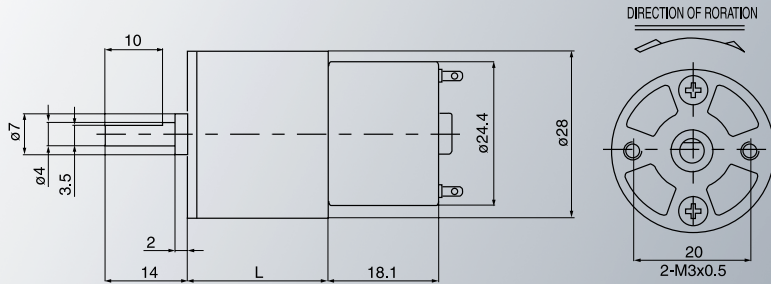

■技术参数 Technical Data

电压 Voltage(VDC)	3V	3V	3V	3V	3V	6V	6V	6V	6V	6V
马达型号 Motor Model	40Q	40Q	40Q	40Q	40Q	52Q	52Q	52Q	52Q	52Q
减速比 Reduction Ratio	1/13	1/31	1/74	1/147	1/348	1/13	1/31	1/74	1/147	1/348
齿轮箱长度 Gearbox Length(mm)	20	20	20	25	25	20	20	20	25	25
空载转速 No-Load Speed(Rpm)	308	129	54	27	11	400	168	70	35	15
额定转速 Rated Speed(Rpm)	234	98	41	21	9	304	127	53	27	11
额定力矩 Rated Torque(Kg.cm)	0.04	0.10	0.23	0.43	1.02	0.03	0.07	0.17	0.32	0.76
额定电流 Rated Current(Amp)	0.12	0.12	0.12	0.12	0.12	0.06	0.06	0.06	0.06	0.06
短时间最大负载 Max.Momentary Torque(Kg.cm)	0.06	0.14	0.34	0.64	1.53	0.05	0.11	0.26	0.48	1.14

ZGA28RP

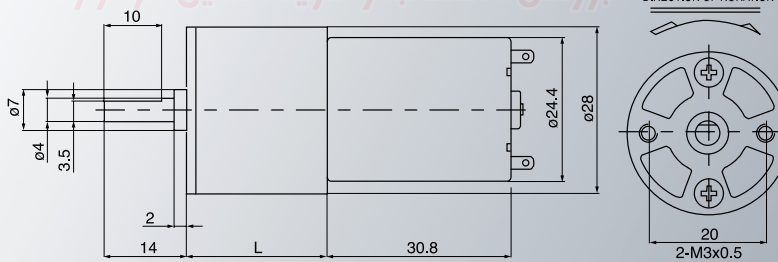

■技术参数 Technical Data

电压 Voltage(VDC)	12V	12V	12V	12V	12V	24V	24V	24V	24V	24V
马达型号 Motor Model	56P	56P	56P	56P	56P	47P	47P	47P	47P	47P
减速比 Reduction Ratio	1/13	1/31	1/74	1/174	1/348	1/13	1/31	1/74	1/174	1/348
齿轮箱长度 Gearbox Length(mm)	20	20	20	25	25	20	20	20	25	25
空载转速 No-Load Speed(Rpm)	431	181	76	32	16	362	152	64	27	14
额定转速 Rated Speed(Rpm)	327	137	57	24	12	275	115	48	21	10
额定力矩 Rated Torque(Kg.cm)	0.24	0.57	1.38	3.11	6.1	0.28	0.67	1.59	3.56	7.12
额定电流 Rated Current(Amp)	0.20	0.20	0.20	0.20	0.20	0.10	0.10	0.10	0.10	0.10
短时间最大负载 Max.Momentary Torque(Kg.cm)	0.36	0.86	2.07	4.66	9.32	0.42	1.00	2.39	5.34	10.68

★备注: 1. 若需要其它规格, 敬请来电联系 2. 如若我司以上规格产生变动, 请恕不再另行通知。

Remark: 1.If any specifications else you required are not listed above, Please contact us 2.The specifications are subject to change without notice.

ZGA28RO

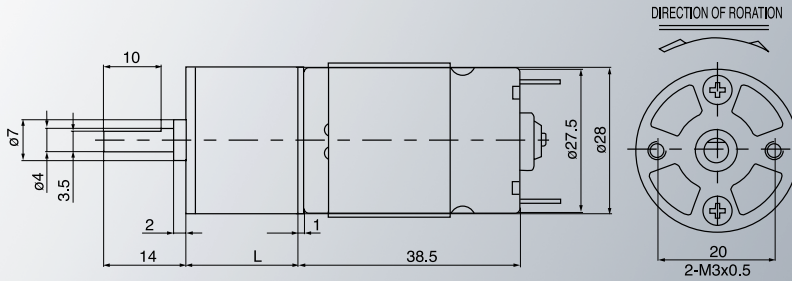

■技术参数 Technical Data

电压 Voltage(VDC)	12V	12V	12V	12V	12V	24V	24V	24V	24V
马达型号 Motor Model	500	500	500	500	500	1000	1000	1000	1000
减速比 Reduction Ratio	1/13	1/31	1/74	1/174	1/348	1/13	1/31	1/74	1/174
齿轮箱长度 Gearbox Length(mm)	20	20	23	25	27	20	20	23	25
空载转速 No-Load Speed(Rpm)	385	161	68	29	14	769	323	135	57
额定转速 Rated Speed(Rpm)	292	123	51	22	11	585	245	103	44
额定力矩 Rated Torque(Kg.cm)	0.50	1.19	2.70	6.04	11.48	0.53	1.26	2.87	6.40
额定电流 Rated Current(Amp)	0.40	0.40	0.40	0.40	0.40	0.50	0.50	0.50	0.50
短时间最大负载 Max.Momentary Torque(Kg.cm)	0.75	1.79	4.06	4.06	17.21	0.80	1.90	4.30	9.60

ZGA32RB

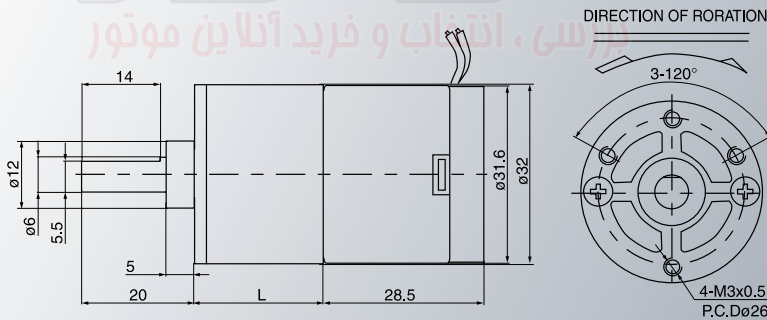

■技术参数 Technical Data

电压 Voltage(VDC)	12V	12V	12V	12V	12V	24V	24V	24V	24V	24V
马达型号 Motor Model	50B	50B	50B	50B	50B	35B	35B	35B	35B	35B
减速比 Reduction Ratio	1/6	1/14	1/33	1/80	1/191	1/6	1/14	1/33	1/80	1/191
齿轮箱长度 Gearbox Length(mm)	23	23	23	23	25	23	23	23	23	25
空载转速 No-Load Speed(Rpm)	868	362	151	62	26	608	254	106	44	18
额定转速 Rated Speed(Rpm)	659	275	115	47	20	462	193	81	33	14
额定力矩 Rated Torque(Kg.cm)	0.08	0.19	0.45	1.10	2.34	0.12	0.29	0.69	1.66	3.78
额定电流 Rated Current(Amp)	0.17	0.17	0.17	0.17	0.17	0.07	0.07	0.07	0.07	0.07
短时间最大负载 Max.Momentary Torque(Kg.cm)	0.10	0.23	0.56	1.37	2.93	0.18	0.43	1.03	2.49	5.67

★备注: 1.若需要其它规格, 敬请来电联系 2.如若我司以上规格产生变动, 请恕不再另行通知。

Remark: 1.If any specifications else you required are not listed above, Please contact us 2.The specifications are subject to change without notice.

ZGA32RI

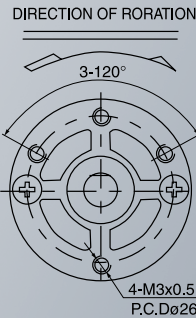
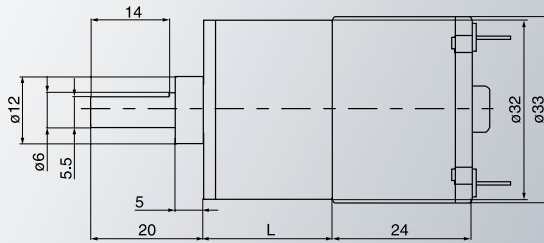

■技术参数 Technical Data

电压 Voltage(VDC)	12V	12V	12V	12V	12V	24V	24V	24V	24V	24V
马达型号 Motor Model	60I	60I	60I	60I	60I	80I	80I	80I	80I	80I
减速比 Reduction Ratio	1/6	1/14	1/33	1/80	1/191	1/6	1/14	1/33	1/80	1/191
齿轮箱长度 Gearbox Length(mm)	23	23	23	23	25	23	23	23	23	25
空载转速 No-Load Speed(Rpm)	1042	435	182	75	31	1389	580	242	101	42
额定转速 Rated Speed(Rpm)	792	330	138	57	24	1056	441	184	76	32
额定力矩 Rated Torque(Kg.cm)	0.10	0.24	0.57	1.38	3.15	0.14	0.34	0.80	1.93	4.41
额定电流 Rated Current(Amp)	0.25	0.25	0.25	0.25	0.25	0.30	0.30	0.30	0.30	0.30
短时间最大负载 Max.Momentary Torque(Kg.cm)	0.15	0.36	0.86	2.07	4.73	0.21	0.50	1.20	2.90	6.62

ZGB33RV

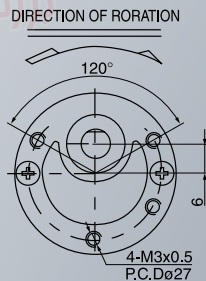
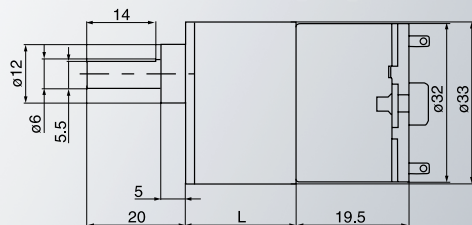

■技术参数 Technical Data

电压 Voltage(VDC)	12V	12V	12V	12V	12V	12V
马达型号 Motor Model	50V	50V	50V	50V	50V	50V
减速比 Reduction Ratio	1/8	1/18	1/52	1/106	1/255	1/611
齿轮箱长度 Gearbox Length(mm)	23	23	23	23	25	27
空载转速 No-Load Speed(Rpm)	657	271	96	47	20	8
额定转速 Rated Speed(Rpm)	500	206	73	35	15	6
额定力矩 Rated Torque(Kg.cm)	0.10	0.25	0.69	1.45	3.07	6.98
额定电流 Rated Current(Amp)	0.17	0.17	0.17	0.17	0.17	0.71
短时间最大负载 Max.Momentary Torque(Kg.cm)	0.13	0.31	0.87	1.81	3.84	8.73

★备注: 1. 若需要其它规格, 敬请来电联系 2. 如若我司以上规格产生变动, 请恕不再另行通知。

Remark: 1. If any specifications else you required are not listed above, Please contact us 2. The specifications are subject to change without notice.

ZGB33RO

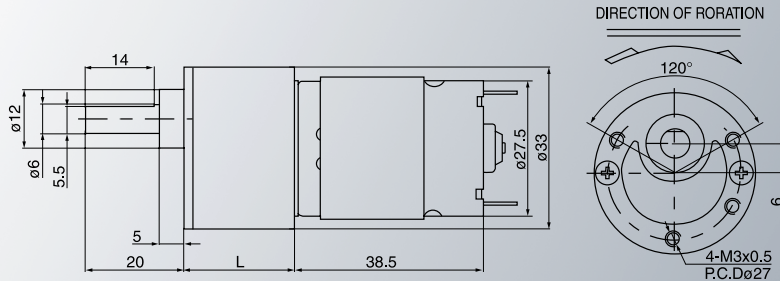

■技术参数 Technical Data

电压 Voltage(VDC)	12V	12V	12V	12V	12V	24V	24V	24V	24V	24V
马达型号 Motor Model	500	500	500	500	500	1000	1000	1000	1000	1000
减速比 Reduction Ratio	1/8	1/18	1/52	1/106	1/255	1/8	1/18	1/52	1/106	1/255
齿轮箱长度 Gearbox Length(mm)	23	23	23	23	25	23	23	23	23	25
空载转速 No-Load Speed(Rpm)	658	272	96	47	20	1316	543	193	94	39
额定转速 Rated Speed(Rpm)	500	207	73	36	15	1000	413	146	72	30
额定力矩 Rated Torque(Kg.cm)	0.29	0.70	1.98	4.06	8.75	0.31	0.75	2.12	4.33	10.39
额定电流 Rated Current(Amp)	0.40	0.40	0.40	0.40	0.40	0.50	0.50	0.50	0.50	0.50
短时间最大负载 Max.Momentary Torque(Kg.cm)	0.44	1.05	2.97	6.07	13.13	0.47	1.13	3.18	6.49	15.59

ZGA37RB

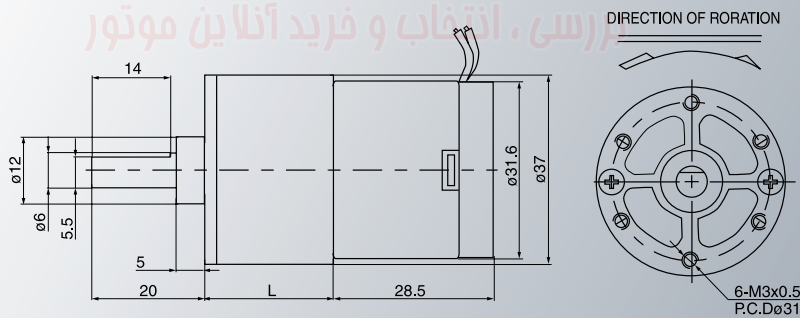

■技术参数 Technical Data

电压 Voltage(VDC)	12V	12V	12V	12V	12V	24V	24V	24V	24V	24V
马达型号 Motor Model	50B	50B	50B	50B	50B	35B	35B	35B	35B	35B
减速比 Reduction Ratio	1/9	1/14	1/99	1/179	1/254	1/9	1/14	1/99	1/179	1/254
齿轮箱长度 Gearbox Length(mm)	23	23	27	30	30	23	23	27	30	30
空载转速 No-Load Speed(Rpm)	568	357	51	28	20	398	250	35	20	14
额定转速 Rated Speed(Rpm)	432	271	38	21	15	302	190	27	15	10
额定力矩 Rated Torque(Kg.cm)	0.12	0.19	1.28	2.20	3.13	0.18	0.29	1.92	3.30	4.69
额定电流 Rated Current(Amp)	0.17	0.17	0.17	0.17	0.17	0.07	0.07	0.07	0.07	0.07
短时间最大负载 Max.Momentary Torque(Kg.cm)	0.18	0.29	1.92	3.30	4.69	0.27	0.43	2.89	4.96	7.03

★备注: 1.若需要其它规格, 敬请来电联系 2.如若我司以上规格产生变动, 请恕不再另行通知。

Remark: 1.If any specifications else you required are not listed above, Please contact us 2.The specifications are subject to change without notice.

ZGB37RB

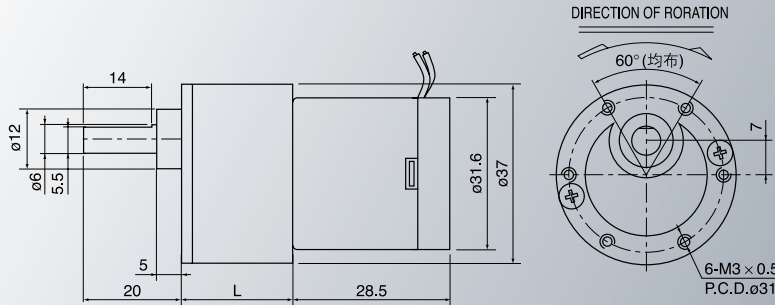

■技术参数 Technical Data

电压 Voltage(VDC)	12V	12V	12V	12V	12V	24V	24V	24V	24V	24V
马达型号 Motor Model	50B	50B	50B	50B	50B	35B	35B	35B	35B	35B
减速比 Reduction Ratio	1/20	1/41	1/83	1/111	1/258	1/20	1/41	1/83	1/111	1/258
齿轮箱长度 Gearbox Length(mm)	23	25	27	27	30	23	25	27	27	30
空载转速 No-Load Speed(Rpm)	250	123	60	45	19	175	86	42	32	14
额定转速 Rated Speed(Rpm)	190	93	45	34	14	133	66	32	24	10
额定力矩 Rated Torque(Kg.cm)	0.27	0.55	1.14	1.51	3.66	0.41	0.83	1.62	2.16	5.02
额定电流 Rated Current(Amp)	0.17	0.17	0.17	0.17	0.17	0.07	0.07	0.07	0.07	0.07
短时间最大负载 Max.Momentary Torque(Kg.cm)	0.41	0.83	1.71	2.26	5.50	0.62	1.25	2.42	3.24	7.54

ZGA37RG

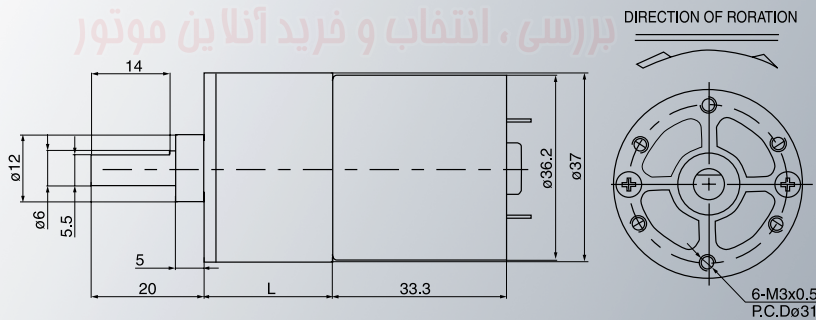

■技术参数 Technical Data

电压 Voltage(VDC)	12V	12V	12V	12V	12V	24V	24V	24V	24V
马达型号 Motor Model	50G	50G	50G	50G	50G	50G	50G	50G	50G
减速比 Reduction Ratio	1/9	1/14	1/99	1/179	1/254	1/9	1/14	1/99	1/179
齿轮箱长度 Gearbox Length(mm)	23	23	27	30	30	23	23	27	30
空载转速 No-Load Speed(Rpm)	568	357	51	28	20	568	357	51	28
额定转速 Rated Speed(Rpm)	432	271	38	21	15	432	271	38	21
额定力矩 Rated Torque(Kg.cm)	0.51	0.81	5.45	9.36	13.29	0.58	0.92	6.20	10.65
额定电流 Rated Current(Amp)	0.58	0.58	0.58	0.58	0.58	0.34	0.34	0.34	0.34
短时间最大负载 Max.Momentary Torque(Kg.cm)	0.77	1.22	8.18	14.04	19.93	0.87	1.38	9.30	15.97

★备注: 1. 若需要其它规格, 敬请来电联系 2. 如若我司以上规格产生变动, 请恕不再另行通知。

Remark: 1.If any specifications else you required are not listed above, Please contact us 2.The specifications are subject to change without notice.

ZGB37RG

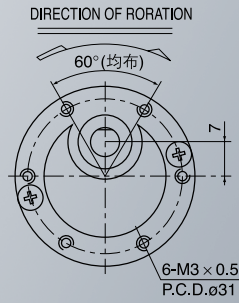
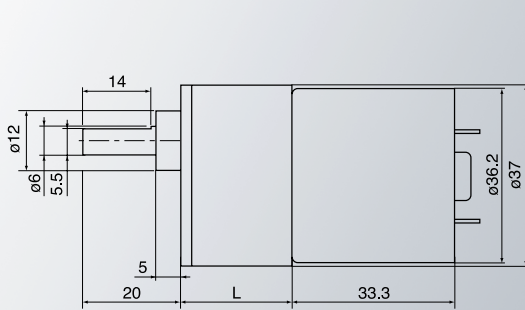

■技术参数 Technical Data

电压 Voltage(VDC)	12V	12V	12V	12V	12V	24V	24V	24V	24V	24V
马达型号 Motor Model	50G	50G	50G	50G	50G	50G	50G	50G	50G	50G
减速比 Reduction Ratio	1/20	1/41	1/83	1/111	1/258	1/20	1/41	1/83	1/111	1/258
齿轮箱长度 Gearbox Length(mm)	23	25	27	27	30	23	25	27	27	30
空载转速 No-Load Speed(Rpm)	250	123	60	45	19	250	123	60	45	19
额定转速 Rated Speed(Rpm)	190	94	46	34	15	190	94	46	34	15
额定力矩 Rated Torque(Kg.cm)	1.16	2.35	4.57	6.12	13.51	1.32	2.68	5.20	6.96	15.37
额定电流 Rated Current(Amp)	0.58	0.58	0.58	0.58	0.58	0.34	0.34	0.34	0.34	0.34
短时间最大负载 Max.Momentary Torque(Kg.cm)	1.74	3.53	6.86	9.17	20.26	1.98	4.02	7.81	10.44	23.05

ZGA37RD

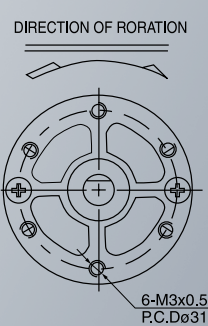
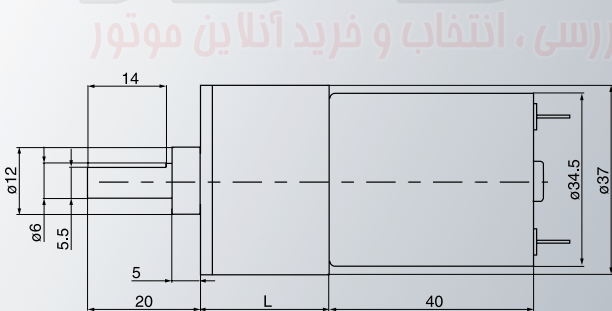

■技术参数 Technical Data

电压 Voltage(VDC)	12V	12V	12V	12V	12V	24V	24V	24V	24V	24V
马达型号 Motor Model	50D	50D	50D	50D	50D	80D	80D	80D	80D	80D
减速比 Reduction Ratio	1/9	1/33	1/77	1/99	1/254	1/9	1/33	1/77	1/99	1/254
齿轮箱长度 Gearbox Length(mm)	23	25	27	30	30	23	25	27	30	30
空载转速 No-Load Speed(Rpm)	568	152	65	51	20	909	242	104	81	31
额定转速 Rated Speed(Rpm)	432	115	49	38	15	691	184	79	61	24
额定力矩 Rated Torque(Kg.cm)	0.45	1.60	3.55	4.34	11.14	0.45	1.69	3.74	4.57	11.14
额定电流 Rated Current(Amp)	0.59	0.59	0.59	0.59	0.59	0.44	0.44	0.44	0.44	0.44
短时间最大负载 Max.Momentary Torque(Kg.cm)	0.68	2.40	5.33	6.51	16.70	0.68	2.53	5.61	6.85	16.70

★备注: 1.若需要其它规格, 敬请来电联系 2.如若我司以上规格产生变动, 请恕不再另行通知。

Remark: 1.If any specifications else you required are not listed above, Please contact us 2.The specifications are subject to change without notice.

ZGB37RD

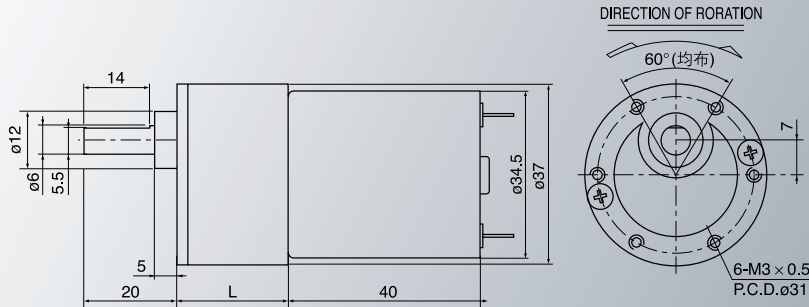

■技术参数 Technical Data

电压 Voltage(VDC)	12V	12V	12V	12V	12V	24V	24V	24V	24V	24V
马达型号 Motor Model	50D	50D	50D	50D	50D	80D	80D	80D	80D	80D
减速比 Reduction Ratio	1/20	1/48	1/83	1/194	1/314	1/20	1/48	1/83	1/194	1/314
齿轮箱长度 Gearbox Length(mm)	23	25	27	30	30	23	25	27	30	30
空载转速 No-Load Speed(Rpm)	250	105	60	25	16	400	168	96	41	25
额定转速 Rated Speed(Rpm)	190	80	45	20	12	304	128	73	31	19
额定力矩 Rated Torque(Kg.cm)	1.40	3.02	4.88	9.99	16.65	1.02	2.30	3.82	8.48	13.73
额定电流 Rated Current(Amp)	0.59	0.59	0.59	0.59	0.59	0.44	0.44	0.44	0.44	0.44
短时间最大负载 Max.Momentary Torque(Kg.cm)	1.75	3.78	6.10	12.49	20.81	1.53	3.45	5.73	12.72	20.60

ZGA37RE

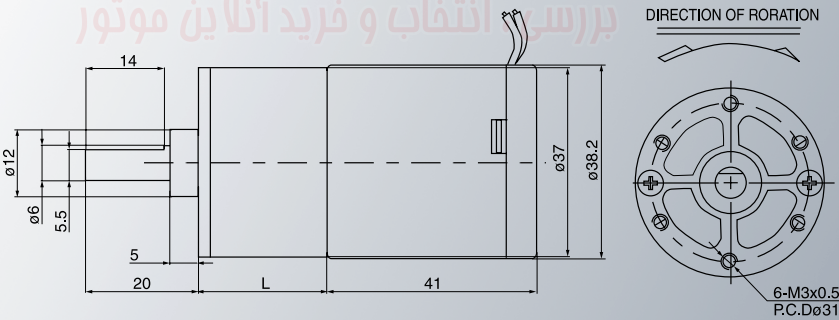

■技术参数 Technical Data

电压 Voltage(VDC)	12V	12V	12V	12V	12V	24V	24V	24V	24V
马达型号 Motor Model	50E	50E	50E	50E	50E	30E	30E	30E	30E
减速比 Reduction Ratio	1/9	1/14	1/33	1/77	1/179	1/9	1/14	1/33	1/77
齿轮箱长度 Gearbox Length(mm)	23	23	25	27	30	23	23	25	27
空载转速 No-Load Speed(Rpm)	568	357	152	65	28	241	214	91	39
额定转速 Rated Speed(Rpm)	432	271	115	49	21	259	163	39	30
额定力矩 Rated Torque(Kg.cm)	0.67	1.07	2.39	5.29	11.68	1.28	1.98	4.52	10.22
额定电流 Rated Current(Amp)	0.76	0.76	0.76	0.76	0.76	0.40	0.40	0.40	0.40
短时间最大负载 Max.Momentary Torque(Kg.cm)	1.01	1.60	3.58	7.94	17.53	1.92	2.96	6.77	15.33

★备注: 1. 若需要其它规格, 敬请来电联系 2. 如若我司以上规格产生变动, 请恕不再另行通知。
Remark: 1.If any specifications else you required are not listed above, Please contact us 2.The specifications are subject to change without notice.

ZGB37RE

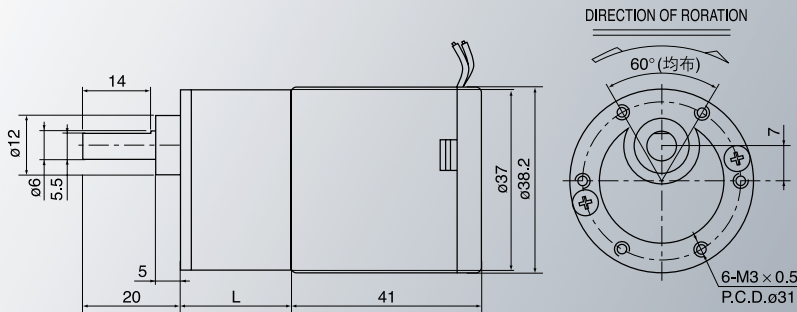

■技术参数 Technical Data

电压 Voltage(VDC)	12V	12V	12V	12V	12V	24V	24V	24V	24V
马达型号 Motor Model	50E	50E	50E	50E	50E	30E	30E	30E	30E
减速比 Reduction Ratio	1/9	1/20	1/48	1/83	1/194	1/9	1/20	1/48	1/83
齿轮箱长度 Gearbox Length(mm)	23	23	25	27	30	23	23	25	27
空载转速 No-Load Speed(Rpm)	575	250	105	60	26	345	150	63	36
额定转速 Rated Speed(Rpm)	437	190	80	46	20	262	114	48	27
额定力矩 Rated Torque(Kg.cm)	0.66	1.52	3.46	5.80	13.02	1.27	2.92	6.66	11.17
额定电流 Rated Current(Amp)	0.76	0.76	0.76	0.76	0.76	0.40	0.40	0.40	0.40
短时间最大负载 Max.Momentary Torque(Kg.cm)	0.99	2.28	5.19	8.70	19.53	1.91	4.38	9.98	16.75

ZGA37RH

555-120VDC/5300RPM

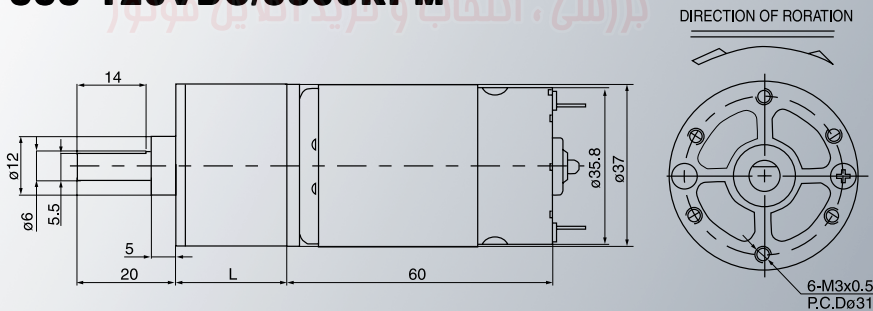

■技术参数 Technical Data

电压 Voltage(VDC)	12V	12V	12V	12V	12V	24V	24V	24V	24V
马达型号 Motor Model	53H	53H	53H	53H	53H	53H	53H	53H	53H
减速比 Reduction Ratio	1/11	1/20	1/47	1/72	1/139	1/11	1/20	1/47	1/72
齿轮箱长度 Gearbox Length(mm)	23	25	27	27	30	23	25	27	27
空载转速 No-Load Speed(Rpm)	482	265	113	74	38	482	265	113	74
额定转速 Rated Speed(Rpm)	366	201	86	56	29	366	201	86	56
额定力矩 Rated Torque(Kg.cm)	1.55	2.56	5.51	8.35	15.04	2.03	3.69	8.24	12.62
额定电流 Rated Current(Amp)	1.10	1.10	1.10	1.10	1.10	0.85	0.85	0.85	0.85
短时间最大负载 Max.Momentary Torque(Kg.cm)	2.32	3.84	8.27	12.53	22.56	3.05	5.54	12.36	18.93

★备注: 1.若需要其它规格, 敬请来电联系 2.如若我司以上规格产生变动, 请恕不再另行通知。

Remark: 1.If any specifications else you required are not listed above, Please contact us 2.The specifications are subject to change without notice.

ZGB37RH

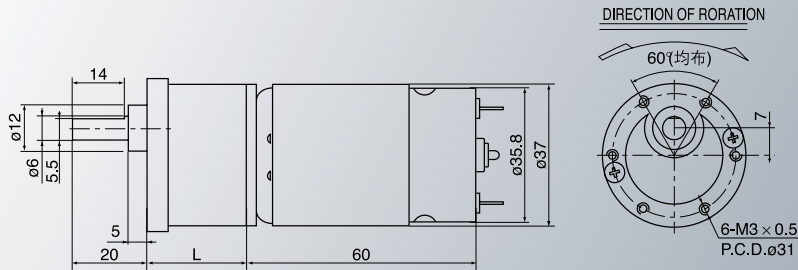

■技术参数 Technical Data

电压 Voltage(VDC)	12V	12V	12V	12V	12V	24V	24V	24V
马达型号 Motor Model	53H	53H	53H	53H	53H	53H	53H	53H
减速比 Reduction Ratio	1/12	1/31	1/64	1/150	1/171	1/12	1/31	1/64
齿轮箱长度 Gearbox Length(mm)	23	25	27	30	30	23	25	27
空载转速 No-Load Speed(Rpm)	449	171	83	35	31	449	171	83
额定转速 Rated Speed(Rpm)	341	130	63	27	24	341	130	63
额定力矩 Rated Torque(Kg.cm)	1.66	4.14	8.13	18.09	20.62	2.18	5.44	10.67
额定电流 Rated Current(Amp)	1.10	1.10	1.10	1.10	1.10	0.85	0.85	0.85
短时间最大负载 Max.Momentary Torque(Kg.cm)	2.49	6.21	12.19	27.14	30.94	3.27	8.16	16.01

ZGA37REE

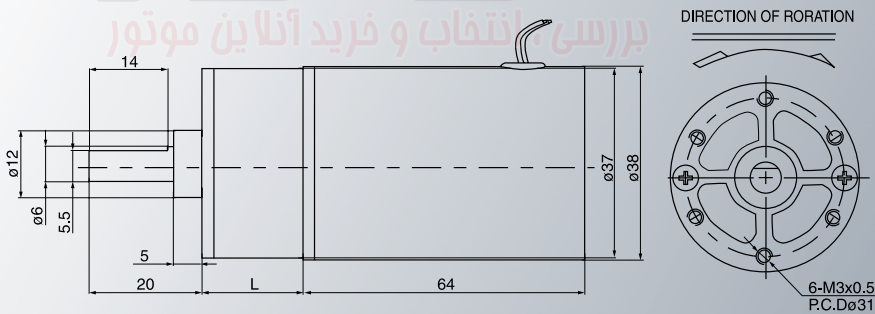

■技术参数 Technical Data

电压 Voltage(VDC)	12V	12V	12V	12V	12V	24V	24V	24V	24V
马达型号 Motor Model	30EE	30EE	30EE	30EE	30EE	35EE	35EE	35EE	35EE
减速比 Reduction Ratio	1/9	1/33	1/77	1/99	1/179	1/9	1/33	1/77	1/99
齿轮箱长度 Gearbox Length(mm)	22	24	26	29	29	22	24	26	29
空载转速 No-Load Speed(Rpm)	341	91	39	30	17	398	106	45	35
额定转速 Rated Speed(Rpm)	259	69	30	23	13	302	81	35	27
额定力矩 Rated Torque(Kg.cm)	1.06	3.78	8.37	10.22	17.56	1.25	4.45	9.87	12.06
额定电流 Rated Current(Amp)	0.55	0.55	0.55	0.55	0.55	0.55	0.55	0.55	0.55
短时间最大负载 Max.Momentary Torque(Kg.cm)	1.33	4.72	10.46	12.78	21.95	1.88	6.68	14.81	18.09

★备注: 1. 若需要其它规格, 敬请来电联系 2. 如若我司以上规格产生变动, 请恕不再另行通知。

Remark: 1. If any specifications else you required are not listed above, Please contact us 2. The specifications are subject to change without notice.

ZGB37REE

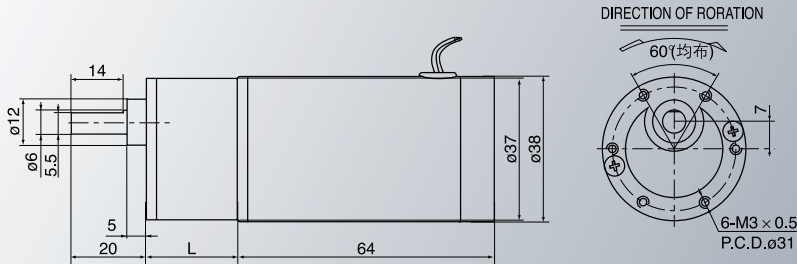

■技术参数 Technical Data

电压 Voltage(VDC)	12V	12V	12V	12V	12V	24V	24V	24V	24V	24V
马达型号 Motor Model	30EE	30EE	30EE	30EE	30EE	35EE	35EE	35EE	35EE	35EE
减速比 Reduction Ratio	1/9	1/20	1/48	1/95	1/148	1/9	1/20	1/48	1/95	1/148
齿轮箱长度 Gearbox Length(mm)	23	23	24	27	26	23	23	24	27	26
空载转速 No-Load Speed(Rpm)	345	150	63	31	20	402	175	74	37	24
额定转速 Rated Speed(Rpm)	262	114	47	24	15	306	133	56	28	18
额定力矩 Rated Torque(Kg.cm)	1.05	2.29	5.28	9.83	15.72	1.23	2.83	6.38	12.11	17.94
额定电流 Rated Current(Amp)	0.55	0.55	0.55	0.55	0.55	0.55	0.55	0.55	0.55	0.55
短时间最大负载 Max.Momentary Torque(Kg.cm)	1.31	2.87	6.60	12.28	19.66	1.54	3.53	7.97	15.14	22.42

ZGA42RG

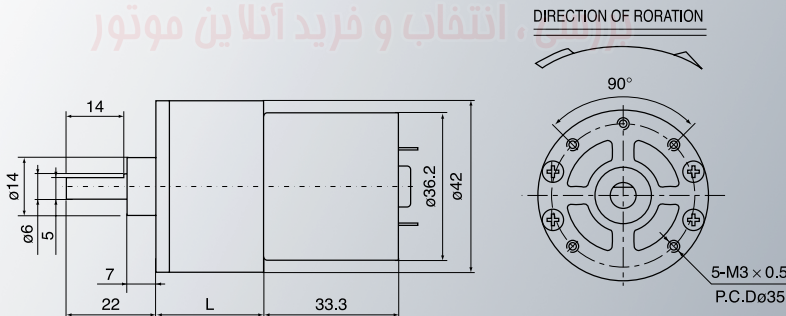

■技术参数 Technical Data

电压 Voltage(VDC)	12V	12V	12V	12V	24V	24V	24V	24V
马达型号 Motor Model	50G	50G	50G	50G	50G	50G	50G	50G
减速比 Reduction Ratio	1/16	1/44	1/117	1/311	1/16	1/44	1/117	1/311
齿轮箱长度 Gearbox Length(mm)	26	26	30	33	26	26	30	33
空载转速 No-Load Speed(Rpm)	305	114	43	16	305	114	43	16
额定转速 Rated Speed(Rpm)	232	86	32	12	232	86	32	12
额定力矩 Rated Torque(Kg.cm)	0.95	2.55	6.44	16.26	1.08	2.90	7.32	18.48
额定电流 Rated Current(Amp)	0.58	0.58	0.58	0.58	0.34	0.34	0.34	0.34
短时间最大负载 Max.Momentary Torque(Kg.cm)	1.19	3.19	8.05	20.32	1.35	3.62	9.15	23.10

★备注: 1. 若需要其它规格, 敬请来电联系 2. 如若我司以上规格产生变动, 请恕不再另行通知。

Remark: 1. If any specifications else you required are not listed above, Please contact us 2. The specifications are subject to change without notice.

ZGB42RG

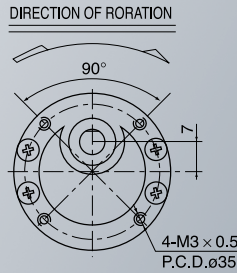
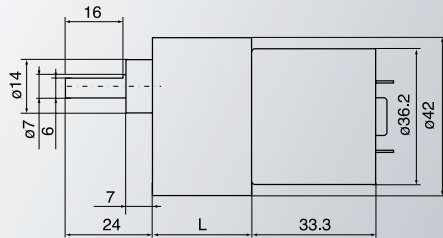

■技术参数 Technical Data

电压 Voltage(VDC)	12V	12V	12V	12V	24V	24V	24V
马达型号 Motor Model	50G	50G	50G	50G	50G	50G	50G
减速比 Reduction Ratio	1/23	1/62	1/166	1/442	1/23	1/62	1/166
齿轮箱长度 Gearbox Length(mm)	27	28	30	33	27	28	30
空载转速 No-Load Speed(Rpm)	217	81	30	11	217	81	30
额定转速 Rated Speed(Rpm)	165	61	23	9	165	61	23
额定力矩 Rated Torque(Kg.cm)	1.33	3.41	8.66	21.91	1.52	4.10	10.42
额定电流 Rated Current(Amp)	0.58	0.58	0.58	0.58	0.34	0.34	0.34
短时间最大负载 Max.Momentary Torque(Kg.cm)	1.66	4.26	10.83	27.39	1.90	5.12	13.03

ZGA42RE

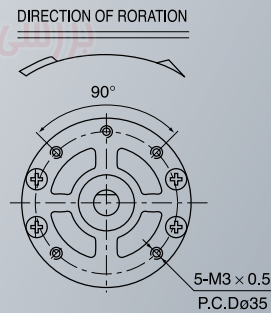
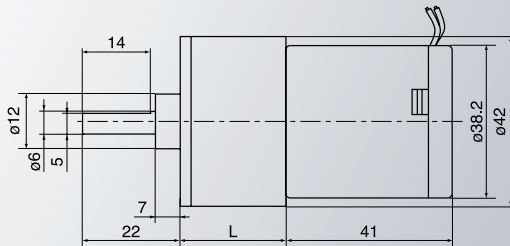

■技术参数 Technical Data

电压 Voltage(VDC)	12V	12V	12V	12V	24V	24V	24V
马达型号 Motor Model	50E	50E	50E	50E	30E	30E	30E
减速比 Reduction Ratio	1/16	1/44	1/117	1/311	1/16	1/44	1/117
齿轮箱长度 Gearbox Length(mm)	26	26	30	33	26	26	30
空载转速 No-Load Speed(Rpm)	305	114	43	16	183	68	26
额定转速 Rated Speed(Rpm)	232	86	32	12	139	52	19
额定力矩 Rated Torque(Kg.cm)	1.24	3.33	8.40	21.22	2.39	6.41	16.20
额定电流 Rated Current(Amp)	0.76	0.76	0.76	0.76	0.40	0.40	0.40
短时间最大负载 Max.Momentary Torque(Kg.cm)	1.86	4.99	12.61	31.83	3.59	9.62	24.30

★备注: 1. 若需要其它规格, 敬请来电联系 2. 如若我司以上规格产生变动, 请恕不再另行通知。
Remark: 1.If any specifications else you required are not listed above, Please contact us 2.The specifications are subject to change without notice.

ZGB42RE

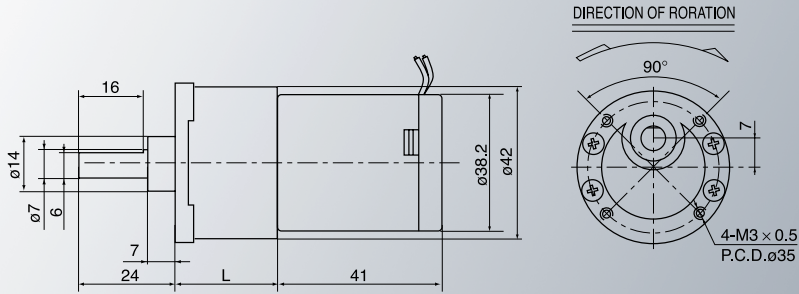

■技术参数 Technical Data

电压 Voltage(VDC)	12V	12V	12V	12V	24V	24V	24V
马达型号 Motor Model	50E	50E	50E	50E	30E	30E	30E
减速比 Reduction Ratio	1/23	1/62	1/166	1/442	1/23	1/62	1/166
齿轮箱长度 Gearbox Length(mm)	27	28	30	33	27	28	30
空载转速 No-Load Speed(Rpm)	217	81	30	11	130	48	18
额定转速 Rated Speed(Rpm)	165	61	23	9	99	37	14
额定力矩 Rated Torque(Kg.cm)	1.74	4.46	11.33	28.67	3.36	9.06	21.83
额定电流 Rated Current(Amp)	0.76	0.76	0.76	0.76	0.40	0.40	0.40
短时间最大负载 Max.Momentary Torque(Kg.cm)	2.18	5.57	14.17	35.84	4.20	11.32	27.28

ZGA42R-38SRZ-1

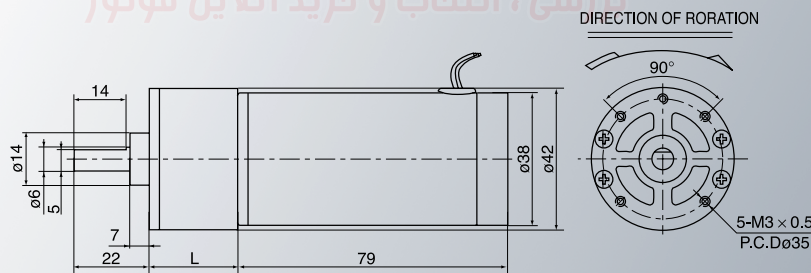

■技术参数 Technical Data

电压 Voltage(VDC)	12V	12V	12V	12V	24V	24V	24V
马达型号 Motor Model	30EE	30EE	30EE	30EE	35EE	35EE	35EE
减速比 Reduction Ratio	23	44	117	311	23	44	117
齿轮箱长度 Gearbox Length(mm)	26	26	30	33	26	26	30
空载转速 No-Load Speed(Rpm)	130	68	26	10	152	80	30
额定转速 Rated Speed(Rpm)	99	52	19	7	116	60	23
额定力矩 Rated Torque(Kg.cm)	2.26	4.32	10.92	27.58	3.25	6.22	14.88
额定电流 Rated Current(Amp)	0.55	0.55	0.55	0.55	0.55	0.55	0.55
短时间最大负载 Max.Momentary Torque(Kg.cm)	2.83	5.40	13.65	34.47	4.06	7.77	18.60

★备注: 1. 若需要其它规格, 敬请来电联系 2. 如若我司以上规格产生变动, 请恕不再另行通知。
Remark: 1. If any specifications else you required are not listed above, Please contact us 2. The specifications are subject to change without notice.

ZGB42R-38SRZ-1

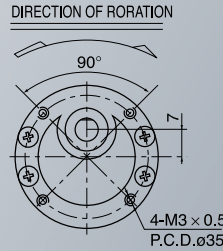
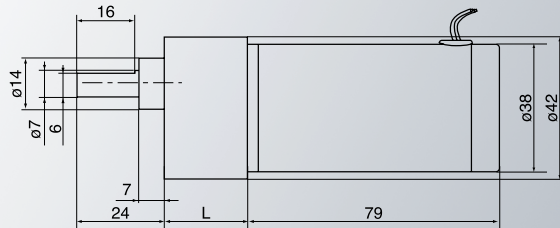

■技术参数 Technical Data

电压 Voltage(VDC)	12V	12V	12V	12V	24V	24V	24V
马达型号 Motor Model	30EE	30EE	30EE	30EE	35EE	35EE	35EE
减速比 Reduction Ratio	23	62	166	442	23	62	166
齿轮箱长度 Gearbox Length(mm)	27	28	30	33	27	28	30
空载转速 No-Load Speed(Rpm)	130	48	18	7	152	56	21
额定转速 Rated Speed(Rpm)	99	37	14	5	116	43	16
额定力矩 Rated Torque(Kg.cm)	2.26	5.79	14.72	35.28	3.25	8.76	22.28
额定电流 Rated Current(Amp)	0.55	0.55	0.55	0.55	0.55	0.20	0.55
短时间最大负载 Max.Momentary Torque(Kg.cm)	3.39	8.68	22.08	52.92	4.88	13.14	33.43

ZGA42RH

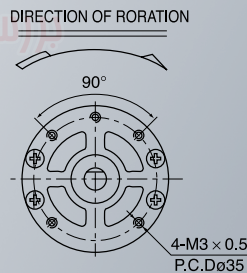
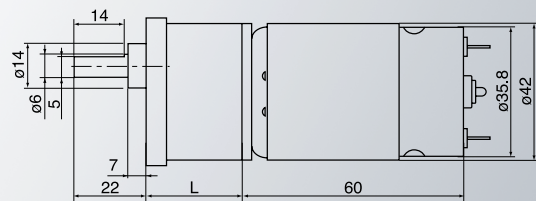

■技术参数 Technical Data

电压 Voltage(VDC)	12V	12V	12V	12V	12V	24V	24V	24V	24V
马达型号 Motor Model	53H	53H	53H	53H	53H	53H	53H	53H	53H
减速比 Reduction Ratio	1/18	1/27	1/59	1/73	1/158	1/18	1/27	1/59	1/73
齿轮箱长度 Gearbox Length(mm)	26	26	30	30	33	26	26	30	30
空载转速 No-Load Speed(Rpm)	294	196	90	73	34	294	196	90	73
额定转速 Rated Speed(Rpm)	224	149	68	55	25	224	149	68	55
额定力矩 Rated Torque(Kg.cm)	2.53	3.61	7.48	8.80	18.09	3.32	4.98	10.34	12.79
额定电流 Rated Current(Amp)	1.10	1.10	1.10	1.10	1.10	0.85	0.85	0.85	0.85
短时间最大负载 Max.Momentary Torque(Kg.cm)	3.16	4.51	9.36	11.00	22.61	4.15	6.23	12.92	15.99

★备注: 1. 若需要其它规格, 敬请来电联系 2. 如若我司以上规格产生变动, 请恕不再另行通知。

Remark: 1. If any specifications else you required are not listed above, Please contact us 2. The specifications are subject to change without notice.

ZGB42RH

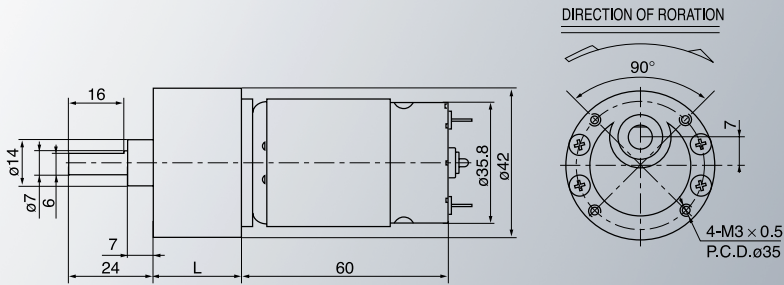

■技术参数 Technical Data

电压 Voltage(VDC)	12V	12V	12V	12V	12V	24V	24V	24V	24V
马达型号 Motor Model	53H	53H	53H	53H	53H	53H	53H	53H	53H
减速比 Reduction Ratio	1/12	1/35	1/83	1/104	1/185	1/12	1/35	1/83	1/104
齿轮箱长度 Gearbox Length(mm)	27	27	28	28	30	27	27	28	28
空载转速 No-Load Speed(Rpm)	442	151	64	51	29	442	151	64	51
额定转速 Rated Speed(Rpm)	336	115	49	39	22	336	115	49	39
额定力矩 Rated Torque(Kg.cm)	1.69	4.93	11.10	13.91	23.51	2.21	6.45	14.52	18.20
额定电流 Rated Current(Amp)	1.10	1.10	1.10	1.10	1.10	0.85	0.85	0.85	0.85
短时间最大负载 Max.Momentary Torque(Kg.cm)	2.11	6.16	13.88	17.39	29.39	2.76	8.06	18.15	22.74

ZGA60RE-G

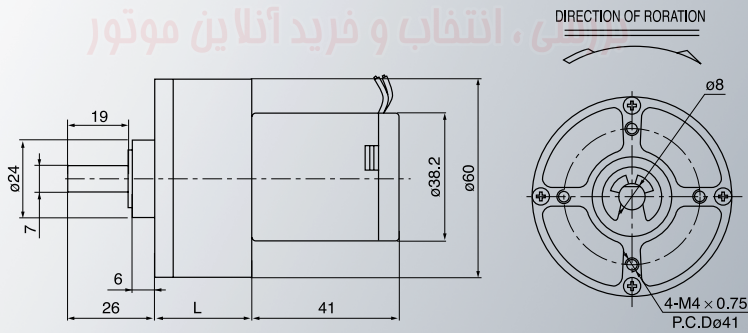

■技术参数 Technical Data

电压 Voltage(VDC)	12V	12V	12V	12V	12V	24V	24V	24V	24V	24V
马达型号 Motor Model	50E	50E	50E	50E	50E	30E	30E	30E	30E	30E
减速比 Reduction Ratio	1/9	1/21	1/31	1/68	1/86	1/9	1/21	1/31	1/68	1/86
齿轮箱长度 Gearbox Length(mm)	28	30	30	33	33	28	30	30	33	33
空载转速 No-Load Speed(Rpm)	543	242	161	74	58	326	145	97	44	35
额定转速 Rated Speed(Rpm)	413	184	123	56	44	248	110	74	34	27
额定力矩 Rated Torque(Kg.cm)	0.70	1.50	2.13	4.44	5.61	1.34	2.86	4.29	8.94	11.30
额定电流 Rated Current(Amp)	0.76	0.76	0.76	0.76	0.76	0.40	0.40	0.40	0.40	0.40
短时间最大负载 Max.Momentary Torque(Kg.cm)	1.05	2.24	3.19	6.65	8.42	2.01	4.30	6.43	13.41	16.96

★备注: 1. 若需要其它规格, 敬请来电联系 2. 如若我司以上规格产生变动, 请恕不再另行通知。

Remark: 1. If any specifications else you required are not listed above, Please contact us 2. The specifications are subject to change without notice.

ZGA60RH-G

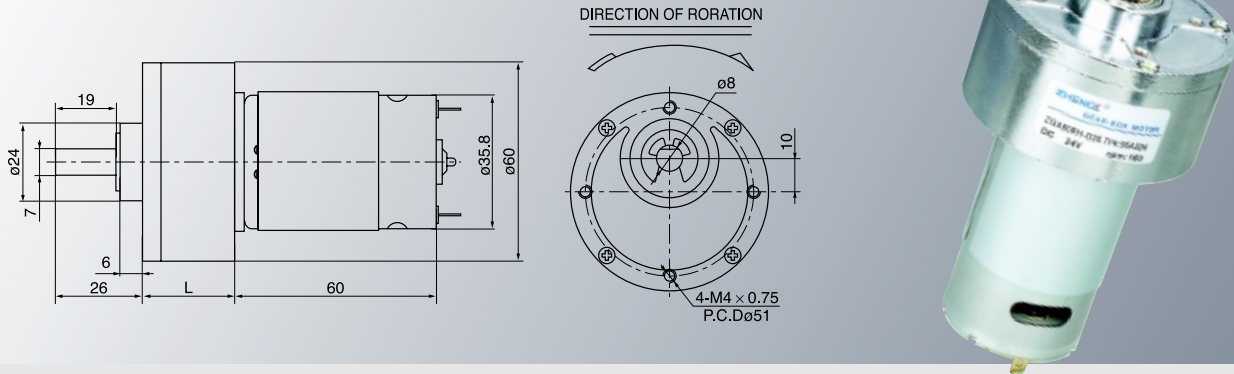

■技术参数 Technical Data

电压 Voltage(VDC)	12V	12V	12V	12V	12V	24V	24V	24V	24V
马达型号 Motor Model	100H	100H	100H	100H	100H	100H	100H	100H	100H
减速比 Reduction Ratio	1/9	1/21	1/26	1/101	1/205	1/9	1/21	1/26	1/101
齿轮箱长度 Gearbox Length(mm)	28	30	30	33	37	28	30	30	33
空载转速 No-Load Speed(Rpm)	1087	483	385	99	49	1087	483	385	99
额定转速 Rated Speed(Rpm)	826	367	292	75	37	826	367	292	75
额定力矩 Rated Torque(Kg.cm)	2.48	5.30	6.3	23.34	45.01	2.71	5.79	7.28	26.85
额定电流 Rated Current(Amp)	4.50	4.50	4.50	4.50	4.50	2.50	2.50	2.50	2.50
短时间最大负载 Max.Momentary Torque(Kg.cm)	3.10	6.63	7.91	29.18	56.26	3.39	7.24	9.09	33.56

ZGA60RM-G

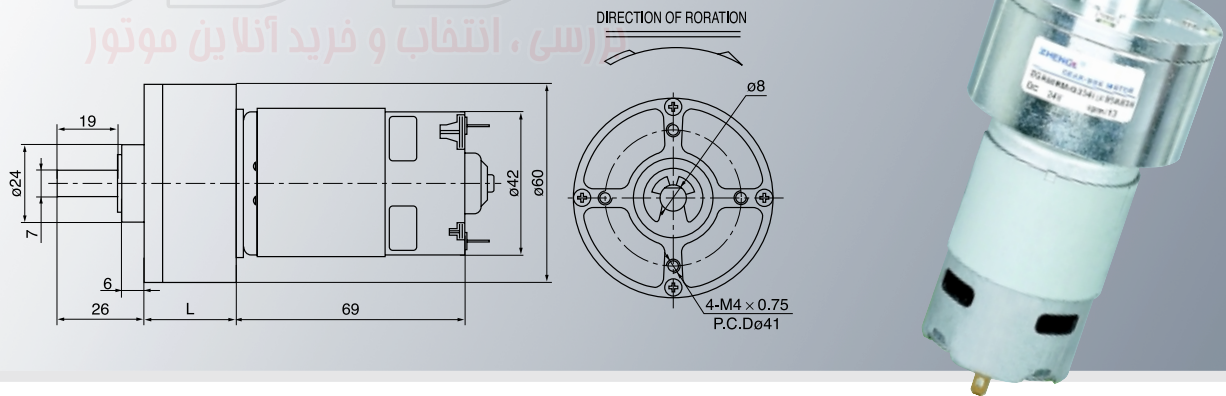

■技术参数 Technical Data

电压 Voltage(VDC)	12V	12V	12V	12V	12V	24V	24V
马达型号 Motor Model	46M	46M	46M	46M	46M	100M	100M
减速比 Reduction Ratio	1/9	1/21	1/101	1/205	1/257	1/9	1/21
齿轮箱长度 Gearbox Length(mm)	28	30	33	37	37	28	30
空载转速 No-Load Speed(Rpm)	500	222	46	22	18	1087	483
额定转速 Rated Speed(Rpm)	380	169	35	17	14	826	367
额定力矩 Rated Torque(Kg.cm)	2.26	4.83	22.39	43.18	54.13	4.74	10.13
额定电流 Rated Current(Amp)	2.00	2.00	2.00	2.00	2.00	3.80	3.80
短时间最大负载 Max.Momentary Torque(Kg.cm)	2.83	6.04	27.99	53.97	67.66	5.93	12.66

★备注: 1. 若需要其它规格, 敬请来电联系 2. 如若我司以上规格产生变动, 请恕不再另行通知。

Remark: 1. If any specifications else you required are not listed above, Please contact us 2. The specifications are subject to change without notice.

ZGA60RHH-G

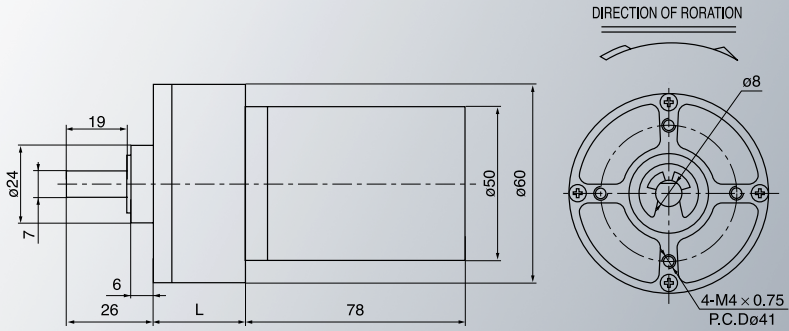

■技术参数 Technical Data

电压 Voltage(VDC)	12V	12V	12V	12V	12V	24V	24V
马达型号 Motor Model	70HH	70HH	70HH	70HH	70HH	60HH	60HH
减速比 Reduction Ratio	1/9	1/20	1/68	1/101	1/225	1/9	1/20
齿轮箱长度 Gearbox Length(mm)	28	30	33	33	37	28	30
空载转速 No-Load Speed(Rpm)	778	350	103	69	31	667	300
额定转速 Rated Speed(Rpm)	591	266	78	53	24	507	228
额定力矩 Rated Torque(Kg.cm)	3.39	7.16	23.12	34.33	72.66	6.00	12.67
额定电流 Rated Current(Amp)	4.80	4.80	4.80	4.80	4.80	4.20	4.20
短时间最大负载 Max.Momentary Torque(Kg.cm)	4.24	8.95	28.90	42.92	90.83	7.50	15.83

ZGA37FB

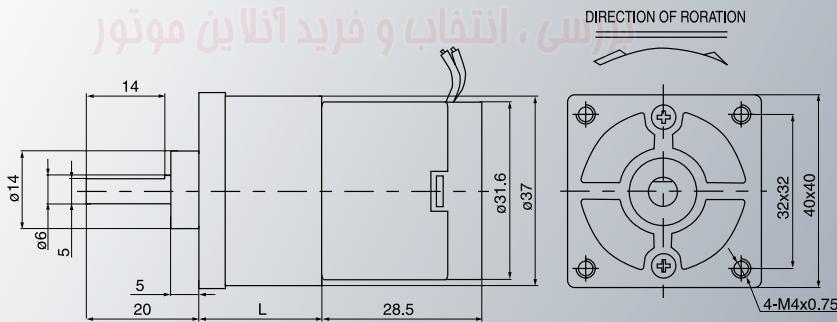

■技术参数 Technical Data

电压 Voltage(VDC)	12V	12V	12V	12V	12V	24V	24V	24V	24V	24V
马达型号 Motor Model	50B	50B	50B	50B	50B	35B	35B	35B	35B	35B
减速比 Reduction Ratio	1/9	1/14	1/99	1/179	1/254	1/9	1/14	1/99	1/179	1/254
齿轮箱长度 Gearbox Length(mm)	23	23	27	30	30	23	23	27	30	30
空载转速 No-Load Speed(Rpm)	568	357	51	28	20	398	250	35	20	14
额定转速 Rated Speed(Rpm)	432	271	38	21	15	302	190	27	15	10
额定力矩 Rated Torque(Kg.cm)	0.12	0.19	1.28	2.20	3.13	0.18	0.29	1.92	3.30	4.69
额定电流 Rated Current(Amp)	0.17	0.17	0.17	0.17	0.17	0.07	0.07	0.07	0.07	0.07
短时间最大负载 Max.Momentary Torque(Kg.cm)	0.18	0.29	1.92	3.30	4.69	0.27	0.43	2.89	4.96	7.03

★备注: 1. 若需要其它规格, 敬请来电联系 2. 如若我司以上规格产生变动, 请恕不再另行通知。

Remark: 1.If any specifications else you required are not listed above, Please contact us 2.The specifications are subject to change without notice.

ZGB37FB

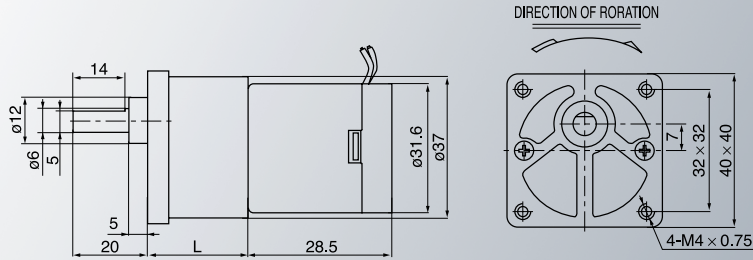

■技术参数 Technical Data

电压 Voltage(VDC)	12V	12V	12V	12V	12V	24V	24V	24V	24V	24V
马达型号 Motor Model	50B	50B	50B	50B	50B	35B	35B	35B	35B	35B
减速比 Reduction Ratio	1/9	1/14	1/99	1/179	1/254	1/9	1/14	1/99	1/179	1/254
齿轮箱长度 Gearbox Length(mm)	23	23	27	30	30	23	23	27	30	30
空载转速 No-Load Speed(Rpm)	568	357	51	28	20	398	250	35	20	14
额定转速 Rated Speed(Rpm)	432	271	38	21	15	302	190	27	15	10
额定力矩 Rated Torque(Kg.cm)	0.12	0.19	1.28	2.20	3.13	0.18	0.29	1.92	3.30	4.69
额定电流 Rated Current(Amp)	0.17	0.17	0.17	0.17	0.17	0.07	0.07	0.07	0.07	0.07
短时间最大负载 Max.Momentary Torque(Kg.cm)	0.18	0.29	1.92	3.30	4.69	0.27	0.43	2.89	4.96	7.03

ZGA37FG

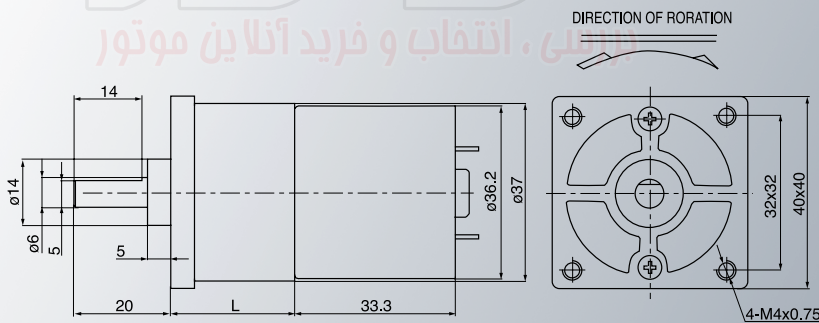

■技术参数 Technical Data

电压 Voltage(VDC)	12V	12V	12V	12V	12V	24V	24V	24V	24V	24V
马达型号 Motor Model	50G	50G	50G	50G	50G	50G	50G	50G	50G	50G
减速比 Reduction Ratio	1/9	1/14	1/99	1/179	1/254	1/9	1/14	1/99	1/179	1/254
齿轮箱长度 Gearbox Length(mm)	23	23	27	30	30	23	23	27	30	30
空载转速 No-Load Speed(Rpm)	568	357	51	28	20	568	357	51	28	20
额定转速 Rated Speed(Rpm)	432	271	38	21	15	432	271	38	21	15
额定力矩 Rated Torque(Kg.cm)	0.51	0.81	5.45	9.36	13.29	0.58	0.92	6.20	10.65	15.11
额定电流 Rated Current(Amp)	0.58	0.58	0.58	0.58	0.58	0.34	0.34	0.34	0.34	0.34
短时间最大负载 Max.Momentary Torque(Kg.cm)	0.77	1.22	8.18	14.04	19.93	0.87	1.38	9.30	15.97	22.66

★备注: 1. 若需要其它规格, 敬请来电联系 2. 如若我司以上规格产生变动, 请恕不再另行通知。

Remark: 1.If any specifications else you required are not listed above, Please contact us 2.The specifications are subject to change without notice.

ZGB37FG

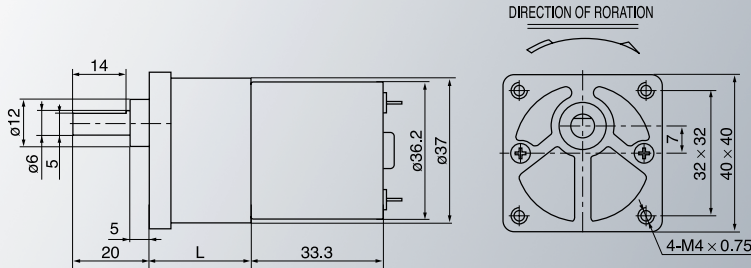

■技术参数 Technical Data

电压 Voltage(VDC)	12V	12V	12V	12V	12V	24V	24V	24V	24V	24V
马达型号 Motor Model	50G	50G	50G	50G	50G	50G	50G	50G	50G	50G
减速比 Reduction Ratio	1/20	1/41	1/83	1/111	1/258	1/20	1/41	1/83	1/111	1/258
齿轮箱长度 Gearbox Length(mm)	23	25	27	27	30	23	25	27	27	30
空载转速 No-Load Speed(Rpm)	250	123	60	45	19	250	123	60	45	19
额定转速 Rated Speed(Rpm)	190	94	46	34	15	190	94	46	34	15
额定力矩 Rated Torque(Kg.cm)	1.16	2.35	4.57	6.12	13.51	1.32	2.68	5.20	6.96	15.37
额定电流 Rated Current(Amp)	0.58	0.58	0.58	0.58	0.58	0.34	0.34	0.34	0.34	0.34
短时间最大负载 Max.Momentary Torque(Kg.cm)	1.74	3.53	6.86	9.17	20.26	1.98	4.02	7.81	10.44	23.05

ZGA37FD

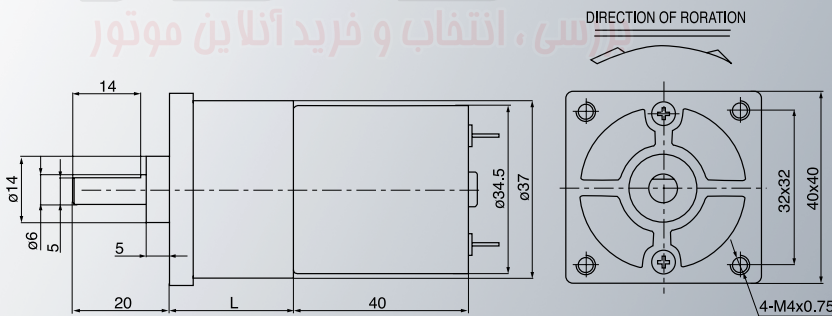

■技术参数 Technical Data

电压 Voltage(VDC)	12V	12V	12V	12V	12V	24V	24V	24V	24V	24V
马达型号 Motor Model	50D	50D	50D	50D	50D	80D	80D	80D	80D	80D
减速比 Reduction Ratio	1/9	1/33	1/77	1/99	1/254	1/9	1/33	1/77	1/99	1/254
齿轮箱长度 Gearbox Length(mm)	23	25	27	30	30	23	25	27	30	30
空载转速 No-Load Speed(Rpm)	568	152	65	51	20	909	242	104	81	31
额定转速 Rated Speed(Rpm)	432	115	49	38	15	691	184	79	61	24
额定力矩 Rated Torque(Kg.cm)	0.45	1.60	3.55	4.34	11.14	0.45	1.69	3.74	4.57	11.14
额定电流 Rated Current(Amp)	0.59	0.59	0.59	0.59	0.59	0.44	0.44	0.44	0.44	0.44
短时间最大负载 Max.Momentary Torque(Kg.cm)	0.68	2.40	5.33	6.51	16.70	0.68	2.53	5.61	6.85	16.70

★备注: 1.若需要其它规格, 敬请来电联系 2.如若我司以上规格产生变动, 请恕不再另行通知。

Remark: 1.If any specifications else you required are not listed above, Please contact us 2.The specifications are subject to change without notice.

ZGB37FD

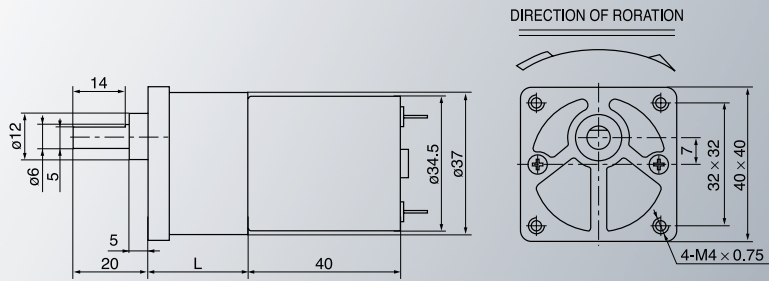

■技术参数 Technical Data

电压 Voltage(VDC)	12V	12V	12V	12V	12V	24V	24V	24V	24V	24V
马达型号 Motor Model	50D	50D	50D	50D	50D	80D	80D	80D	80D	80D
减速比 Reduction Ratio	1/20	1/48	1/83	1/194	1/314	1/20	1/48	1/83	1/194	1/314
齿轮箱长度 Gearbox Length(mm)	23	25	27	30	30	23	25	27	30	30
空载转速 No-Load Speed(Rpm)	250	105	60	25	16	400	168	96	41	25
额定转速 Rated Speed(Rpm)	190	80	45	20	12	304	128	73	31	19
额定力矩 Rated Torque(Kg.cm)	1.40	3.02	4.88	9.99	16.65	1.02	2.30	3.82	8.48	13.73
额定电流 Rated Current(Amp)	0.59	0.59	0.59	0.59	0.59	0.44	0.44	0.44	0.44	0.44
短时间最大负载 Max.Momentary Torque(Kg.cm)	1.75	3.78	6.10	12.49	20.81	1.53	3.45	5.73	12.72	20.60

ZGA37FE

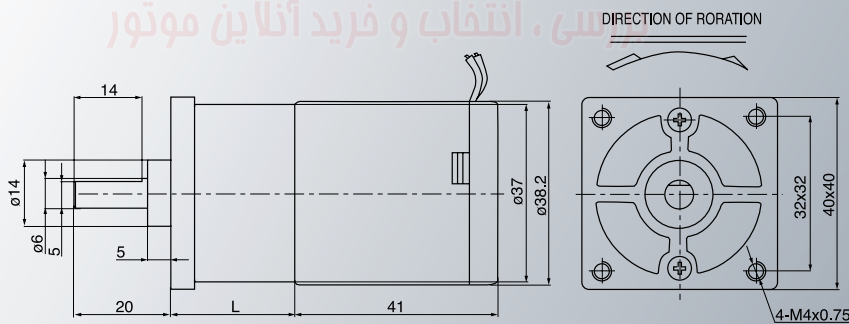

■技术参数 Technical Data

电压 Voltage(VDC)	12V	12V	12V	12V	12V	24V	24V	24V	24V
马达型号 Motor Model	50E	50E	50E	50E	50E	30E	30E	30E	30E
减速比 Reduction Ratio	1/9	1/14	1/33	1/77	1/179	1/9	1/14	1/33	1/77
齿轮箱长度 Gearbox Length(mm)	23	23	25	27	30	23	23	25	27
空载转速 No-Load Speed(Rpm)	568	357	152	65	28	241	214	91	39
额定转速 Rated Speed(Rpm)	432	271	115	49	21	259	163	39	30
额定力矩 Rated Torque(Kg.cm)	0.67	1.07	2.39	5.29	11.68	1.28	1.98	4.52	10.22
额定电流 Rated Current(Amp)	0.76	0.76	0.76	0.76	0.76	0.40	0.40	0.40	0.40
短时间最大负载 Max.Momentary Torque(Kg.cm)	1.01	1.60	3.58	7.94	17.53	1.92	2.96	6.77	15.33

★备注: 1. 若需要其它规格, 敬请来电联系 2. 如若我司以上规格产生变动, 请恕不再另行通知。

Remark: 1.If any specifications else you required are not listed above, Please contact us 2.The specifications are subject to change without notice.

ZGB37FE

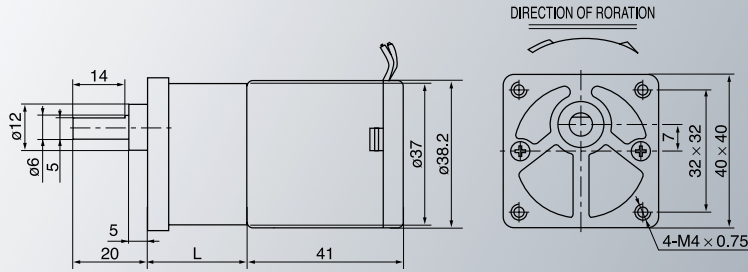

■技术参数 Technical Data

电压 Voltage(VDC)	12V	12V	12V	12V	12V	24V	24V	24V	24V
马达型号 Motor Model	50E	50E	50E	50E	50E	30E	30E	30E	30E
减速比 Reduction Ratio	1/9	1/20	1/48	1/83	1/194	1/9	1/20	1/48	1/83
齿轮箱长度 Gearbox Length(mm)	23	23	25	27	30	23	23	25	27
空载转速 No-Load Speed(Rpm)	575	250	105	60	26	345	150	63	36
额定转速 Rated Speed(Rpm)	437	190	80	46	20	262	114	48	27
额定力矩 Rated Torque(Kg.cm)	0.66	1.52	3.46	5.80	13.02	1.27	2.92	6.66	11.17
额定电流 Rated Current(Amp)	0.76	0.76	0.76	0.76	0.76	0.40	0.40	0.40	0.40
短时间最大负载 Max.Momentary Torque(Kg.cm)	0.99	2.28	5.19	8.70	19.53	1.91	4.38	9.98	16.75

ZGA37FH

555-12VDC/5300RPM

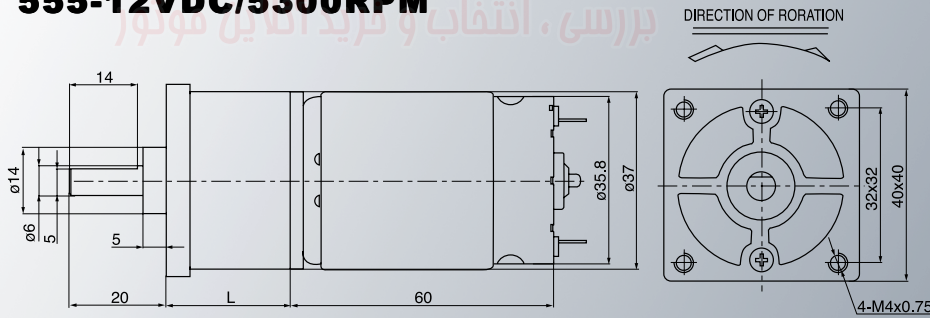

■技术参数 Technical Data

电压 Voltage(VDC)	12V	12V	12V	12V	12V	24V	24V	24V	24V
马达型号 Motor Model	53H	53H	53H	53H	53H	53H	53H	53H	53H
减速比 Reduction Ratio	1/11	1/20	1/47	1/72	1/139	1/11	1/20	1/47	1/72
齿轮箱长度 Gearbox Length(mm)	23	25	27	27	30	23	25	27	27
空载转速 No-Load Speed(Rpm)	482	265	113	74	38	482	265	113	74
额定转速 Rated Speed(Rpm)	366	201	86	56	29	366	201	86	56
额定力矩 Rated Torque(Kg.cm)	1.55	2.56	5.51	8.35	15.04	2.03	3.69	8.24	12.62
额定电流 Rated Current(Amp)	1.10	1.10	1.10	1.10	1.10	0.85	0.85	0.85	0.85
短时间最大负载 Max.Momentary Torque(Kg.cm)	2.32	3.84	8.27	12.53	22.56	3.05	5.54	12.36	18.93

★备注: 1.若需要其它规格, 敬请来电联系 2.如若我司以上规格产生变动, 请恕不再另行通知。

Remark: 1.If any specifications else you required are not listed above, Please contact us 2.The specifications are subject to change without notice.

ZGB37FH

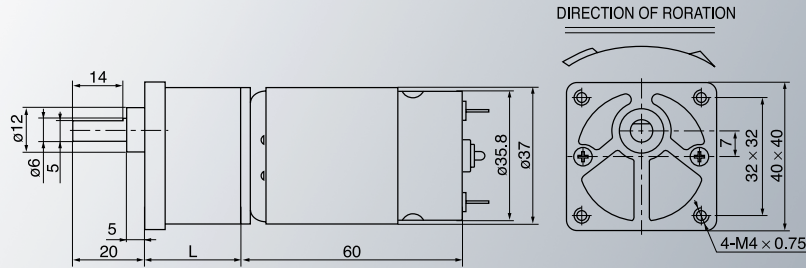

■技术参数 Technical Data

电压 Voltage(VDC)	12V	12V	12V	12V	12V	24V	24V	24V
马达型号 Motor Model	53H	53H	53H	53H	53H	53H	53H	53H
减速比 Reduction Ratio	1/12	1/31	1/64	1/150	1/171	1/12	1/31	1/64
齿轮箱长度 Gearbox Length(mm)	23	25	27	30	30	23	25	27
空载转速 No-Load Speed(Rpm)	449	171	83	35	31	449	171	83
额定转速 Rated Speed(Rpm)	341	130	63	27	24	341	130	63
额定力矩 Rated Torque(Kg.cm)	1.66	4.14	8.13	18.09	20.62	2.18	5.44	10.67
额定电流 Rated Current(Amp)	1.10	1.10	1.10	1.10	1.10	0.85	0.85	0.85
短时间最大负载 Max.Momentary Torque(Kg.cm)	2.49	6.21	12.19	27.14	30.94	3.27	8.16	16.01

ZGA37FEE

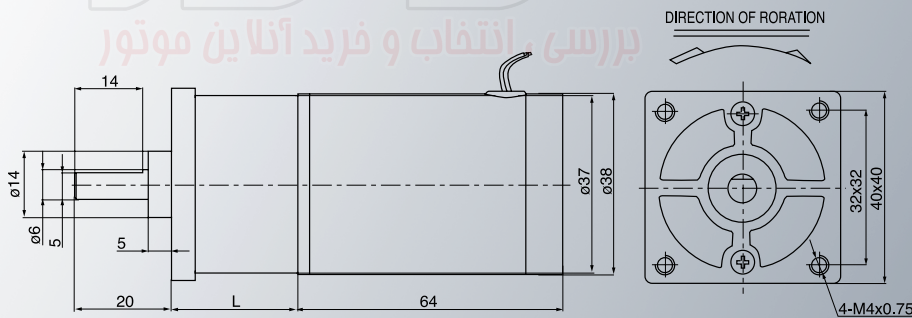

■技术参数 Technical Data

电压 Voltage(VDC)	12V	12V	12V	12V	12V	24V	24V	24V	24V
马达型号 Motor Model	30EE	30EE	30EE	30EE	30EE	35EE	35EE	35EE	35EE
减速比 Reduction Ratio	1/9	1/33	1/77	1/99	1/179	1/9	1/33	1/77	1/99
齿轮箱长度 Gearbox Length(mm)	22	24	26	29	29	22	24	26	29
空载转速 No-Load Speed(Rpm)	341	91	39	30	17	398	106	45	35
额定转速 Rated Speed(Rpm)	259	69	30	23	13	302	81	35	27
额定力矩 Rated Torque(Kg.cm)	1.06	3.78	8.37	10.22	17.56	1.25	4.45	9.87	12.06
额定电流 Rated Current(Amp)	0.55	0.55	0.55	0.55	0.55	0.55	0.55	0.55	0.55
短时间最大负载 Max.Momentary Torque(Kg.cm)	1.33	4.72	10.46	12.78	21.95	1.88	6.68	14.81	18.09

★备注: 1. 若需要其它规格, 敬请来电联系 2. 如若我司以上规格产生变动, 请恕不再另行通知。

Remark: 1.If any specifications else you required are not listed above, Please contact us 2.The specifications are subject to change without notice.

ZGB37FEE

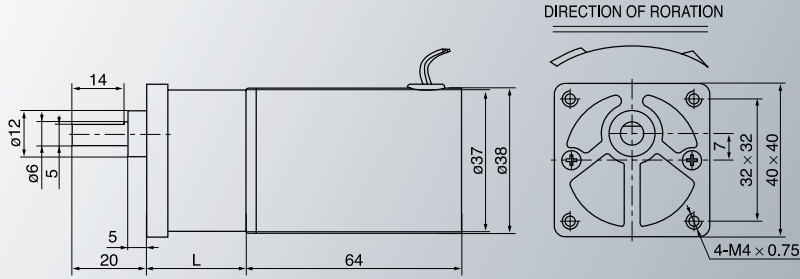

■技术参数 Technical Data

电压 Voltage(VDC)	12V	12V	12V	12V	12V	24V	24V	24V	24V	24V
马达型号 Motor Model	30EE	30EE	30EE	30EE	30EE	35EE	35EE	35EE	35EE	35EE
减速比 Reduction Ratio	1/9	1/20	1/48	1/95	1/148	1/9	1/20	1/48	1/95	1/148
齿轮箱长度 Gearbox Length(mm)	23	23	24	27	26	23	23	24	27	26
空载转速 No-Load Speed(Rpm)	345	150	63	31	20	402	175	74	37	24
额定转速 Rated Speed(Rpm)	262	114	47	24	15	306	133	56	28	18
额定力矩 Rated Torque(Kg.cm)	1.05	2.29	5.28	9.83	15.72	1.23	2.83	6.38	12.11	17.94
额定电流 Rated Current(Amp)	0.55	0.55	0.55	0.55	0.55	0.55	0.55	0.55	0.55	0.55
短时间最大负载 Max.Momentary Torque(Kg.cm)	1.31	2.87	6.60	12.28	19.66	1.54	3.53	7.97	15.14	22.42

ZGA42FG

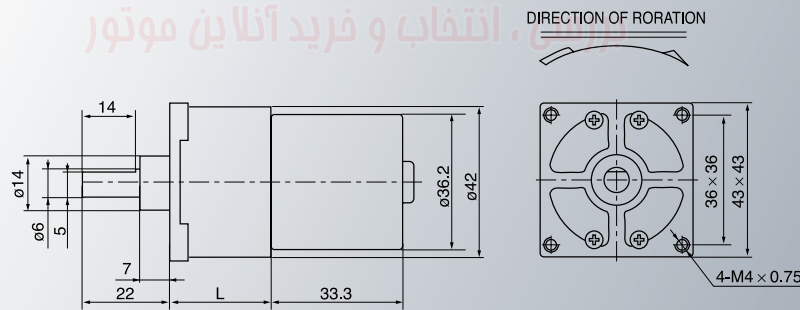

■技术参数 Technical Data

电压 Voltage(VDC)	12V	12V	12V	12V	24V	24V	24V	24V
马达型号 Motor Model	50G	50G	50G	50G	50G	50G	50G	50G
减速比 Reduction Ratio	1/16	1/44	1/117	1/311	1/16	1/44	1/117	1/311
齿轮箱长度 Gearbox Length(mm)	26	26	30	33	26	26	30	33
空载转速 No-Load Speed(Rpm)	305	114	43	16	305	114	43	16
额定转速 Rated Speed(Rpm)	232	86	32	12	232	86	32	12
额定力矩 Rated Torque(Kg.cm)	0.95	2.55	6.44	16.26	1.08	2.90	7.32	18.48
额定电流 Rated Current(Amp)	0.58	0.58	0.58	0.58	0.34	0.34	0.34	0.34
短时间最大负载 Max.Momentary Torque(Kg.cm)	1.19	3.19	8.05	20.30	1.35	3.62	9.15	23.10

★备注: 1. 若需要其它规格, 敬请来电联系 2. 如若我司以上规格产生变动, 请恕不再另行通知。

Remark: 1.If any specifications else you required are not listed above, Please contact us 2.The specifications are subject to change without notice.

ZGA42FE

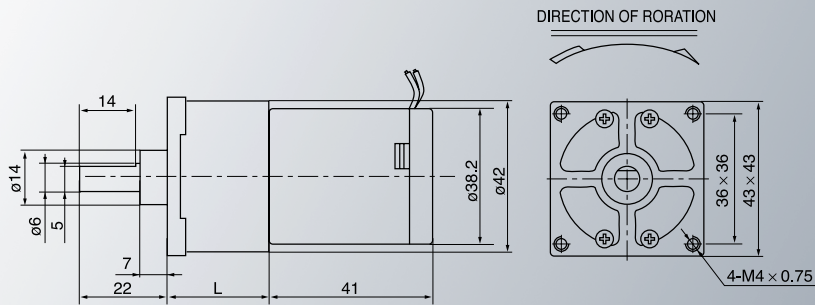

■技术参数 Technical Data

电压 Voltage(VDC)	12V	12V	12V	12V	24V	24V	24V
马达型号 Motor Model	50E	50E	50E	50E	30E	30E	30E
减速比 Reduction Ratio	1/16	1/44	1/117	1/311	1/16	1/44	1/117
齿轮箱长度 Gearbox Length(mm)	26	26	30	33	26	26	30
空载转速 No-Load Speed(Rpm)	305	114	43	16	183	68	26
额定转速 Rated Speed(Rpm)	232	86	32	12	139	52	19
额定力矩 Rated Torque(Kg.cm)	1.24	3.33	8.40	21.22	2.39	6.41	16.20
额定电流 Rated Current(Amp)	0.76	0.76	0.76	0.76	0.40	0.40	0.40
短时间最大负载 Max.Momentary Torque(Kg.cm)	1.86	4.99	12.61	31.83	3.59	9.62	24.30

ZGB42FE

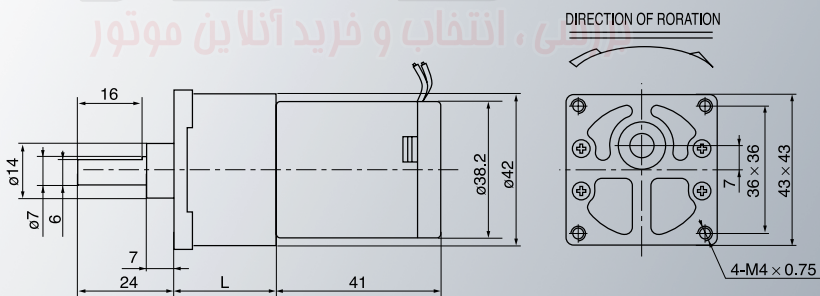

■技术参数 Technical Data

电压 Voltage(VDC)	12V	12V	12V	12V	24V	24V	24V
马达型号 Motor Model	50E	50E	50E	50E	30E	30E	30E
减速比 Reduction Ratio	1/23	1/62	1/166	1/442	1/23	1/62	1/166
齿轮箱长度 Gearbox Length(mm)	27	28	30	33	27	28	30
空载转速 No-Load Speed(Rpm)	217	81	30	11	130	48	18
额定转速 Rated Speed(Rpm)	165	61	23	9	99	37	14
额定力矩 Rated Torque(Kg.cm)	1.74	4.46	11.33	28.67	3.36	9.06	21.83
额定电流 Rated Current(Amp)	0.76	0.76	0.76	0.76	0.40	0.40	0.40
短时间最大负载 Max.Momentary Torque(Kg.cm)	2.18	5.57	14.17	35.84	4.20	11.32	27.28

★备注: 1. 若需要其它规格, 敬请来电联系 2. 如若我司以上规格产生变动, 请恕不再另行通知。
Remark: 1.If any specifications else you required are not listed above, Please contact us 2.The specifications are subject to change without notice.

ZGA42F-38SRZ-1

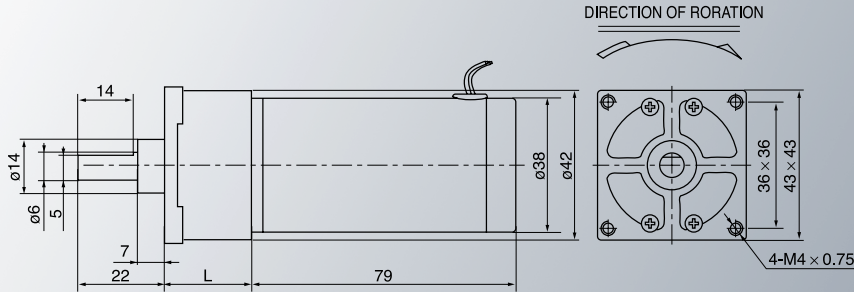

■技术参数 Technical Data

电压 Voltage(VDC)	12V	12V	12V	12V	24V	24V	24V	24V
马达型号 Motor Model	30EE	30EE	30EE	30EE	35EE	35EE	35EE	35EE
减速比 Reduction Ratio	23	44	117	311	23	44	117	311
齿轮箱长度 Gearbox Length(mm)	26	26	30	33	26	26	30	33
空载转速 No-Load Speed(Rpm)	130	68	26	10	152	80	30	11
额定转速 Rated Speed(Rpm)	99	52	19	7	116	60	23	9
额定力矩 Rated Torque(Kg.cm)	2.26	4.32	10.92	27.58	3.25	6.22	14.88	35.60
额定电流 Rated Current(Amp)	0.55	0.55	0.55	0.55	0.55	0.55	0.55	0.55
短时间最大负载 Max.Momentary Torque(Kg.cm)	2.83	5.40	13.65	34.47	4.06	7.77	18.60	44.49

ZGB42F-38SRZ-1

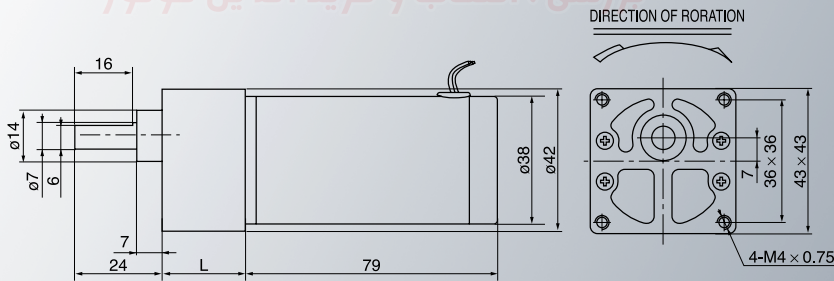

■技术参数 Technical Data

电压 Voltage(VDC)	12V	12V	12V	12V	24V	24V	24V	24V
马达型号 Motor Model	30EE	30EE	30EE	30EE	35EE	35EE	35EE	35EE
减速比 Reduction Ratio	23	62	166	442	23	62	166	442
齿轮箱长度 Gearbox Length(mm)	27	28	30	33	27	28	30	33
空载转速 No-Load Speed(Rpm)	130	48	18	7	152	56	21	8
额定转速 Rated Speed(Rpm)	99	37	14	5	116	43	16	6
额定力矩 Rated Torque(Kg.cm)	2.26	5.79	14.72	35.28	3.25	8.76	22.28	47.47
额定电流 Rated Current(Amp)	0.55	0.55	0.55	0.55	0.55	0.20	0.55	0.55
短时间最大负载 Max.Momentary Torque(Kg.cm)	3.39	8.68	22.08	52.92	4.88	13.14	33.43	59.33

★备注: 1. 若需要其它规格, 敬请来电联系 2. 如若我司以上规格产生变动, 请恕不再另行通知。

Remark: 1. If any specifications else you required are not listed above, Please contact us 2. The specifications are subject to change without notice.

ZGA42FH

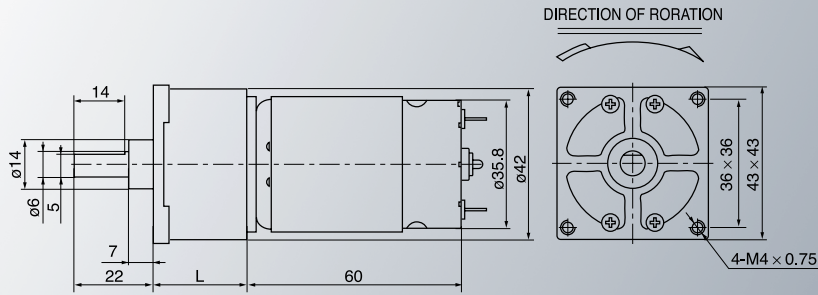

■技术参数 Technical Data

电压 Voltage(VDC)	12V	12V	12V	12V	12V	24V	24V	24V	24V
马达型号 Motor Model	53H	53H	53H	53H	53H	53H	53H	53H	53H
减速比 Reduction Ratio	1/18	1/27	1/59	1/73	1/158	1/18	1/27	1/59	1/73
齿轮箱长度 Gearbox Length(mm)	26	26	30	30	33	26	26	30	30
空载转速 No-Load Speed(Rpm)	294	196	90	73	34	294	196	90	73
额定转速 Rated Speed(Rpm)	224	149	68	55	25	224	149	68	55
额定力矩 Rated Torque(Kg.cm)	2.53	3.61	7.48	8.80	18.09	3.32	4.98	10.34	12.79
额定电流 Rated Current(Amp)	1.10	1.10	1.10	1.10	1.10	0.85	0.85	0.85	0.85
短时间最大负载 Max.Momentary Torque(Kg.cm)	3.16	4.51	9.36	11.00	22.61	4.15	6.23	12.92	15.99

ZGB42FH

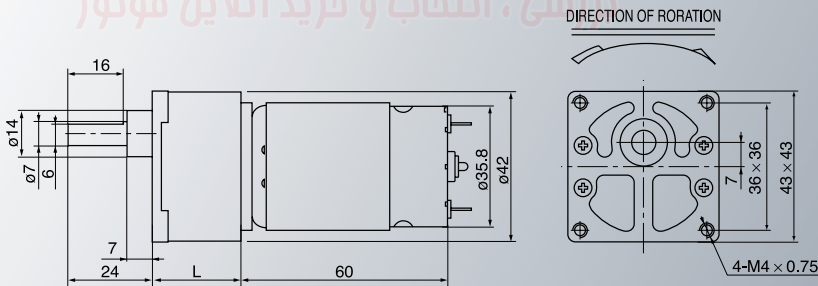

■技术参数 Technical Data

电压 Voltage(VDC)	12V	12V	12V	12V	12V	24V	24V	24V	24V
马达型号 Motor Model	53H	53H	53H	53H	53H	53H	53H	53H	53H
减速比 Reduction Ratio	1/12	1/35	1/83	1/104	1/185	1/12	1/35	1/83	1/104
齿轮箱长度 Gearbox Length(mm)	27	27	28	28	30	27	27	28	28
空载转速 No-Load Speed(Rpm)	442	151	64	51	29	442	151	64	51
额定转速 Rated Speed(Rpm)	336	115	49	39	22	336	115	49	39
额定力矩 Rated Torque(Kg.cm)	1.69	4.93	11.10	13.91	23.51	2.21	6.45	14.52	18.20
额定电流 Rated Current(Amp)	1.10	1.10	1.10	1.10	1.10	0.85	0.85	0.85	0.85
短时间最大负载 Max.Momentary Torque(Kg.cm)	2.11	6.16	13.88	17.39	29.39	2.76	8.06	18.15	22.74

★备注: 1. 若需要其它规格, 敬请来电联系 2. 如若我司以上规格产生变动, 请恕不再另行通知。
Remark: 1.If any specifications else you required are not listed above, Please contact us 2.The specifications are subject to change without notice.

ZGA60FE-G

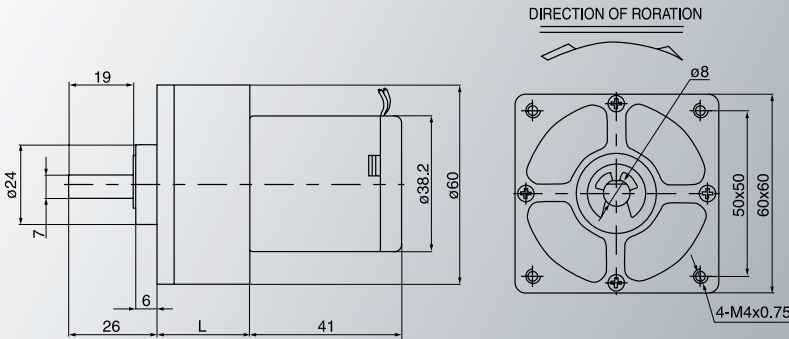

■技术参数 Technical Data

电压 Voltage(VDC)	12V	12V	12V	12V	12V	24V	24V	24V	24V	24V
马达型号 Motor Model	50E	50E	50E	50E	50E	30E	30E	30E	30E	30E
减速比 Reduction Ratio	1/9	1/21	1/31	1/68	1/86	1/9	1/21	1/31	1/68	1/86
齿轮箱长度 Gearbox Length(mm)	28	30	30	33	33	28	30	30	33	33
空载转速 No-Load Speed(Rpm)	543	242	161	74	58	326	145	97	44	35
额定转速 Rated Speed(Rpm)	413	184	123	56	44	248	110	74	34	27
额定力矩 Rated Torque(Kg.cm)	0.70	1.50	2.13	4.44	5.61	1.34	2.86	4.29	8.94	11.30
额定电流 Rated Current(Amp)	0.76	0.76	0.76	0.76	0.76	0.40	0.40	0.40	0.40	0.40
短时间最大负载 Max.Momentary Torque(Kg.cm)	1.05	2.24	3.19	6.65	8.42	2.01	4.30	6.43	13.41	16.96

ZGB60FE-G

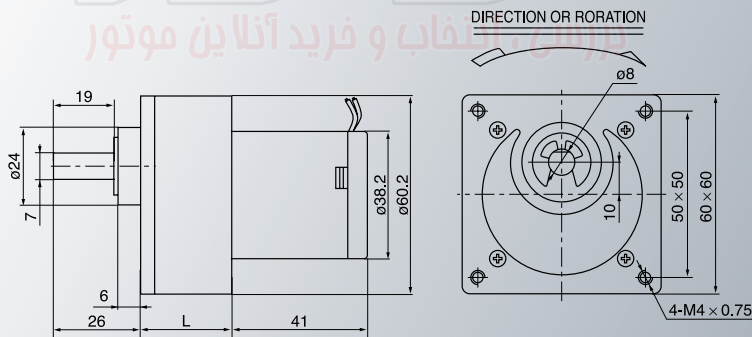

■技术参数 Technical Data

电压 Voltage(VDC)	12V	12V	12V	12V	12V	24V	24V	24V	24V	24V
马达型号 Motor Model	50E	50E	50E	50E	50E	30E	30E	30E	30E	30E
减速比 Reduction Ratio	1/19	1/28	1/62	1/92	1/205	1/19	1/28	1/62	1/93	1/205
齿轮箱长度 Gearbox Length(mm)	30	30	33	33	37	30	30	33	33	37
空载转速 No-Load Speed(Rpm)	263	179	81	54	24	158	107	48	33	15
额定转速 Rated Speed(Rpm)	200	136	61	41	19	120	81	37	25	11
额定力矩 Rated Torque(Kg.cm)	1.45	2.03	4.27	6.02	12.74	2.77	3.88	8.59	12.10	25.62
额定电流 Rated Current(Amp)	0.76	0.76	0.76	0.76	0.76	0.40	0.40	0.40	0.40	0.40
短时间最大负载 Max.Momentary Torque(Kg.cm)	2.18	3.05	6.41	9.03	19.11	4.16	5.82	12.88	18.16	38.44

★备注: 1. 若需要其它规格, 敬请来电联系 2. 如若我司以上规格产生变动, 请恕不再另行通知。

Remark: 1. If any specifications else you required are not listed above, Please contact us 2. The specifications are subject to change without notice.

ZGA60FH-G

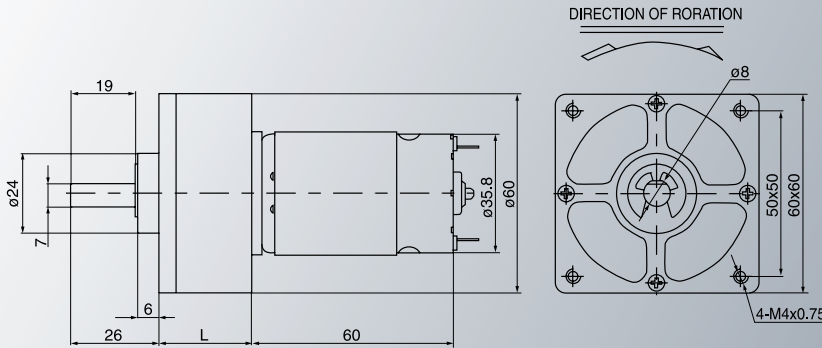

■技术参数 Technical Data

电压 Voltage(VDC)	12V	12V	12V	12V	24V	24V	24V	24V
马达型号 Motor Model	100H	100H	100H	100H	100H	100H	100H	100H
减速比 Reduction Ratio	1/9	1/21	1/26	1/101	1/9	1/21	1/26	1/101
齿轮箱长度 Gearbox Length(mm)	28	30	30	33	28	30	30	33
空载转速 No-Load Speed(Rpm)	1087	483	385	99	1087	483	385	99
额定转速 Rated Speed(Rpm)	826	367	292	75	826	367	292	75
额定力矩 Rated Torque(Kg.cm)	2.48	5.30	6.33	23.34	2.71	5.79	7.28	26.85
额定电流 Rated Current(Amp)	4.50	4.50	4.50	4.50	2.50	2.50	2.50	2.50
短时间最大负载 Max.Momentary Torque(Kg.cm)	3.10	6.63	7.91	29.18	3.39	7.24	9.09	33.56

ZGB60FH-G

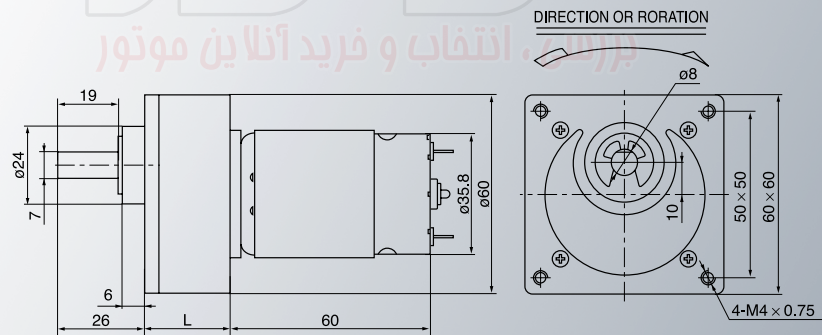

■技术参数 Technical Data

电压 Voltage(VDC)	12V	12V	12V	12V	24V	24V	24V	24V
马达型号 Motor Model	100H	100H	100H	100H	100H	100H	100H	100H
减速比 Reduction Ratio	1/19	1/28	1/62	1/92	1/19	1/28	1/62	1/92
齿轮箱长度 Gearbox Length(mm)	30	30	33	33	30	30	33	33
空载转速 No-Load Speed(Rpm)	526	357	161	109	526	357	161	109
额定转速 Rated Speed(Rpm)	400	271	123	83	400	271	123	83
额定力矩 Rated Torque(Kg.cm)	5.12	7.17	15.08	21.26	5.60	7.84	17.36	24.47
额定电流 Rated Current(Amp)	4.50	4.50	4.50	4.50	2.50	2.50	2.50	2.50
短时间最大负载 Max.Momentary Torque(Kg.cm)	6.40	8.96	18.85	26.57	7.00	9.80	21.70	30.59

★备注: 1. 若需要其它规格, 敬请来电联系 2. 如若我司以上规格产生变动, 请恕不再另行通知。
Remark: 1.If any specifications else you required are not listed above, Please contact us 2.The specifications are subject to change without notice.

ZGA60FM-G

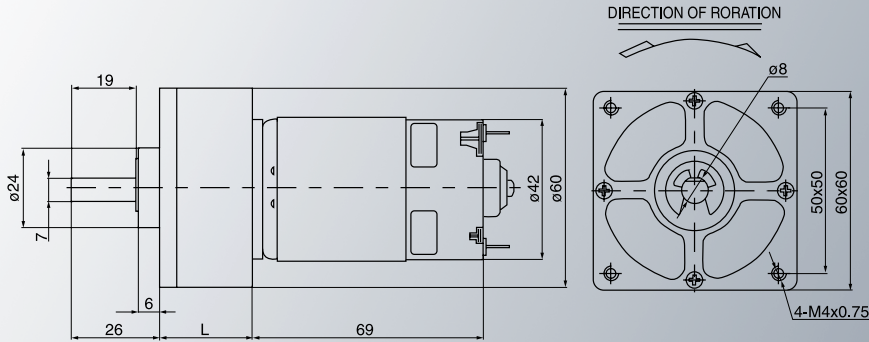

■技术参数 Technical Data

电压 Voltage(VDC)	12V	12V	12V	12V	12V	24V	24V
马达型号 Motor Model	46M	46M	46M	46M	46M	100M	100M
减速比 Reduction Ratio	1/9	1/21	1/101	1/205	1/257	1/9	1/21
齿轮箱长度 Gearbox Length(mm)	28	30	33	37	37	28	30
空载转速 No-Load Speed(Rpm)	500	222	46	22	18	1087	483
额定转速 Rated Speed(Rpm)	380	169	35	17	14	826	367
额定力矩 Rated Torque(Kg.cm)	2.26	4.83	22.39	43.18	54.13	4.74	10.13
额定电流 Rated Current(Amp)	2.00	2.00	2.00	2.00	2.00	3.80	3.80
短时间最大负载 Max.Momentary Torque(Kg.cm)	2.83	6.04	27.99	53.97	67.66	5.93	12.66

ZGB60FM-G

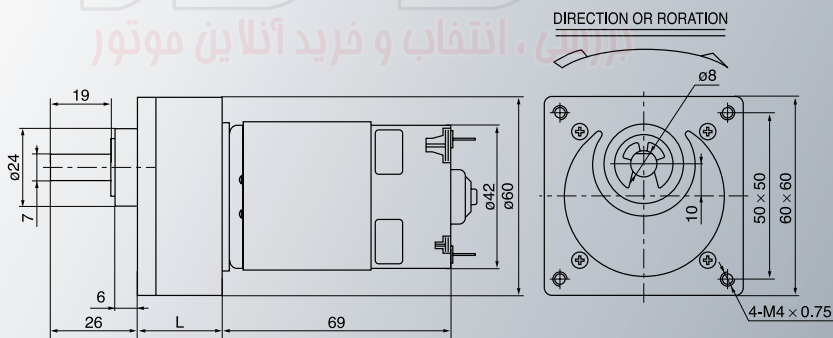

■技术参数 Technical Data

电压 Voltage(VDC)	12V	12V	12V	12V	12V	24V	24V	24V
马达型号 Motor Model	46M	46M	46M	46M	46M	100M	100M	100M
减速比 Reduction Ratio	1/19	1/28	1/62	1/92	1/205	1/19	1/28	1/62
齿轮箱长度 Gearbox Length(mm)	30	30	33	33	37	30	30	33
空载转速 No-Load Speed(Rpm)	242	164	74	50	22	526	357	161
额定转速 Rated Speed(Rpm)	184	125	56	38	17	400	271	123
额定力矩 Rated Torque(Kg.cm)	4.67	6.54	13.75	19.39	43.20	9.78	13.69	28.80
额定电流 Rated Current(Amp)	2.00	2.00	2.00	2.00	2.00	3.80	3.80	3.80
短时间最大负载 Max.Momentary Torque(Kg.cm)	5.84	8.17	17.19	24.23	54.00	12.23	17.12	36.00

★备注: 1. 若需要其它规格, 敬请来电联系 2. 如若我司以上规格产生变动, 请恕不再另行通知。

Remark: 1.If any specifications else you required are not listed above, Please contact us 2.The specifications are subject to change without notice.

ZGA60FHH-G

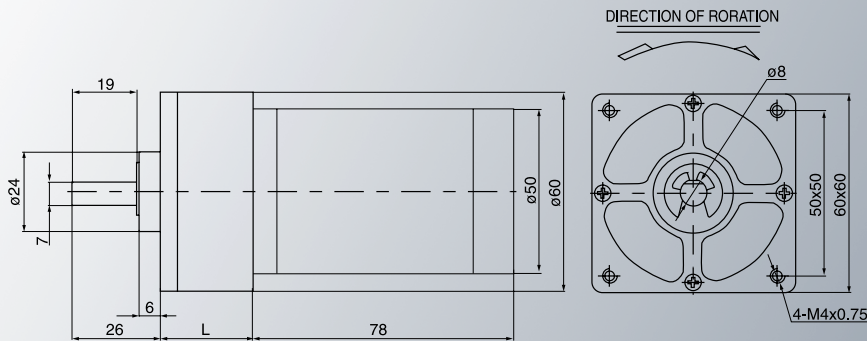

■技术参数 Technical Data

电压 Voltage(VDC)	12V	12V	12V	12V	12V	24V	24V
马达型号 Motor Model	70HH	70HH	70HH	70HH	70HH	60HH	60HH
减速比 Reduction Ratio	1/9	1/20	1/68	1/101	1/225	1/9	1/20
齿轮箱长度 Gearbox Length(mm)	28	30	33	33	37	28	30
空载转速 No-Load Speed(Rpm)	778	350	103	69	31	667	300
额定转速 Rated Speed(Rpm)	591	266	78	53	24	507	228
额定力矩 Rated Torque(Kg.cm)	3.39	7.16	23.12	34.33	72.66	6.00	12.67
额定电流 Rated Current(Amp)	4.80	4.80	4.80	4.80	4.80	4.20	4.20
短时间最大负载 Max.Momentary Torque(Kg.cm)	4.24	8.95	28.90	42.92	90.83	7.50	15.83

ZGB60FHH-G

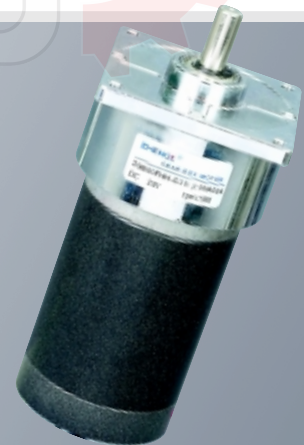
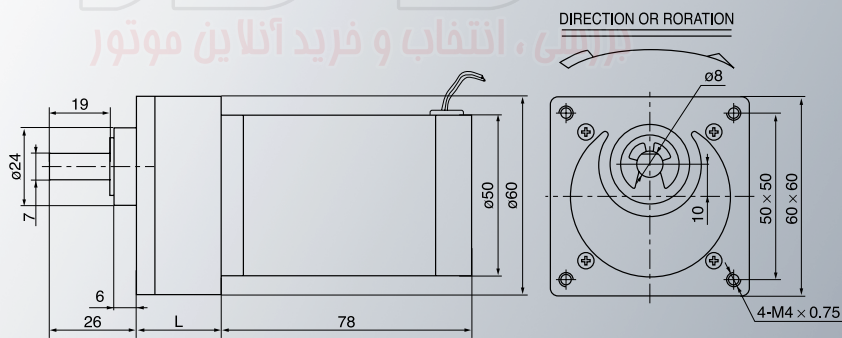

■技术参数 Technical Data

电压 Voltage(VDC)	12V	12V	12V	12V	12V	24V	24V
马达型号 Motor Model	70HH	70HH	70HH	70HH	70HH	60HH	60HH
减速比 Reduction Ratio	1/19	1/28	1/62	1/92	1/205	1/19	1/28
齿轮箱长度 Gearbox Length(mm)	28	30	33	33	37	28	30
空载转速 No-Load Speed(Rpm)	368	250	113	76	34	316	214
额定转速 Rated Speed(Rpm)	280	190	86	58	26	240	163
额定力矩 Rated Torque(Kg.cm)	7.16	10.02	21.09	31.29	66.23	12.68	17.75
额定电流 Rated Current(Amp)	4.80	4.80	4.80	4.80	4.80	4.20	4.20
短时间最大负载 Max.Momentary Torque(Kg.cm)	8.95	12.53	26.36	39.11	82.79	15.85	22.19

★备注: 1. 若需要其它规格, 敬请来电联系 2. 如若我司以上规格产生变动, 请恕不再另行通知。

Remark: 1. If any specifications else you required are not listed above, Please contact us 2. The specifications are subject to change without notice.

ZGB60R-45SRZ 45S-24VDC/2500RPM

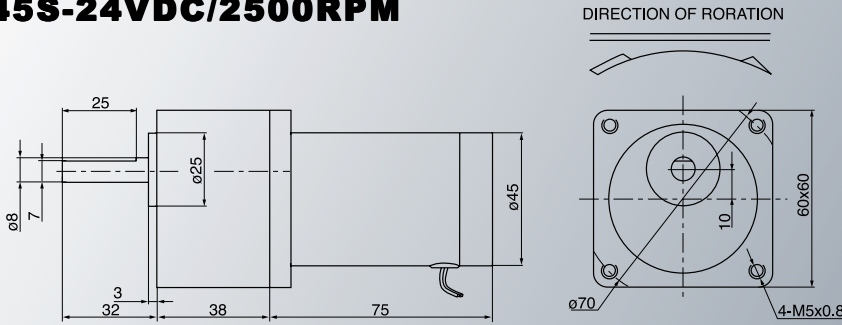

■技术参数 Technical Data

电压 Voltage(VDC)	24V	24V	24V	24V	24V	24V
马达型号 Motor Model	25GG	25GG	25GG	25GG	25GG	25GG
减速比 Reduction Ratio	1/10	1/15	1/35	1/66	1/110	1/200
齿轮箱长度 Gearbox Length(mm)	38.00	38.00	38.00	38.00	38.00	38.00
空载转速 No-Load Speed(Rpm)	250	167	71	38	23	13
额定转速 Rated Speed(Rpm)	190	127	54	29	17	10
额定力矩 Rated Torque(Kg.cm)	2.90	4.35	10.15	19.14	31.90	58.00
额定电流 Rated Current(Amp)	0.57	0.57	0.57	0.57	0.57	0.57
短时间最大负载 Max.Momentary Torque(Kg.cm)	3.63	5.44	12.69	23.93	39.88	72.50

ZGB60R-50SRZ-1 50S-24VDC/2000RPM

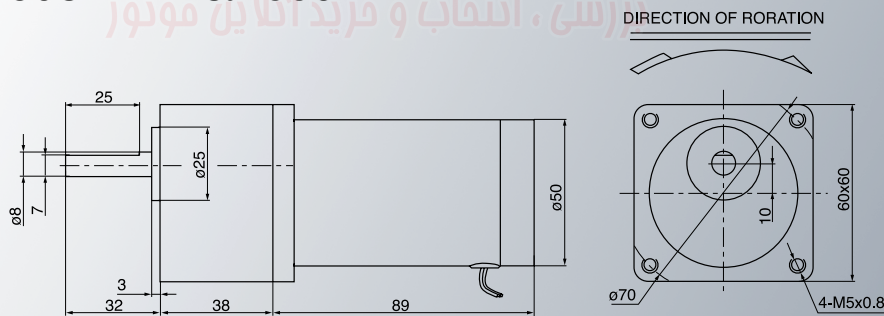

■技术参数 Technical Data

电压 Voltage(VDC)	24V	24V	24V	24V	24V	24V
马达型号 Motor Model	20HH	200HH	20HH	20HH	20	20HH
减速比 Reduction Ratio	1/10	1/15	1/35	1/66	1/11	1/200
齿轮箱长度 Gearbox Length(mm)	38.00	38.00	38.00	38.00	38.00	38.00
空载转速 No-Load Speed(Rpm)	200	133	57	30	18	10
额定转速 Rated Speed(Rpm)	152	101	43	23	14	8
额定力矩 Rated Torque(Kg.cm)	5.30	7.95	18.55	34.98	58.30	106.00
额定电流 Rated Current(Amp)	0.70	0.70	0.70	0.70	0.70	0.70
短时间最大负载 Max.Momentary Torque(Kg.cm)	6.63	9.94	23.19	43.73	72.88	13.50

★备注: 1. 若需要其它规格, 敬请来电联系 2. 如若我司以上规格产生变动, 请恕不再另行通知。

Remark: 1. If any specifications else you required are not listed above, Please contact us 2. The specifications are subject to change without notice.

ZGB60R-60SRZ-1

60S-1-24VDC/2000RPM

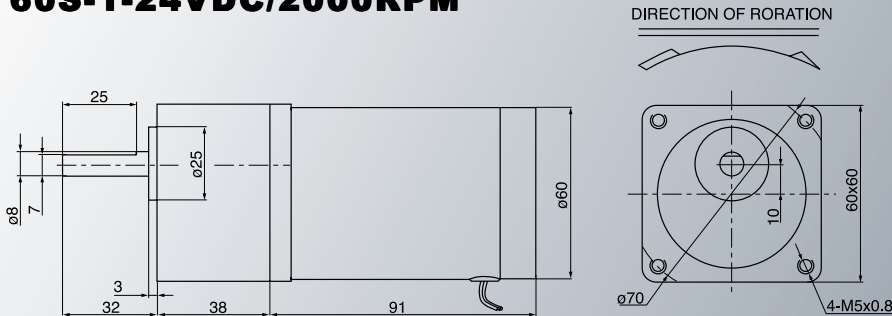

■技术参数 Technical Data

电压 Voltage(VDC)	24V	24V	24V	24V	24V	24V
马达型号 Motor Model	20MM-1	20MM-1	20MM-1	20MM-1	20MM-1	20MM-1
减速比 Reduction Ratio	1/5	1/10	1/20	1/30	1/55	1/110
齿轮箱长度 Gearbox Length(mm)	38.00	38.00	38.00	38.00	38.00	38.00
空载转速 No-Load Speed(Rpm)	400	200	100	67	36	18
额定转速 Rated Speed(Rpm)	304	152	76	51	28	14
额定力矩 Rated Torque(Kg.cm)	3.45	6.90	13.80	20.70	37.95	75.90
额定电流 Rated Current(Amp)	1.00	1.00	1.00	1.00	1.00	1.00
短时间最大负载 Max.Momentary Torque(Kg.cm)	4.31	8.63	17.25	25.88	47.44	94.8

ZGB70R-60SRZ-1

60S-1-24VDC/2000RPM

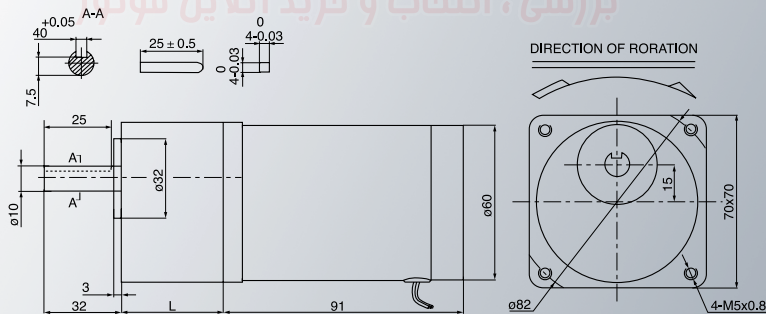

■技术参数 Technical Data

电压 Voltage(VDC)	24V	24V	24V	24V	24V	24V
马达型号 Motor Model	20MM-1	20MM-1	20MM-1	20MM-1	20MM-1	20MM-1
减速比 Reduction Ratio	1/4.5	1/9.1	1/15	1/49	1/88	1/135
齿轮箱长度 Gearbox Length(mm)	36.00	36.00	36.00	36.00	42.00	42.00
空载转速 No-Load Speed(Rpm)	444	220	133	41	23	15
额定转速 Rated Speed(Rpm)	338	167	101	31	17	11
额定力矩 Rated Torque(Kg.cm)	3.12	6.31	10.40	33.97	61.01	93.60
额定电流 Rated Current(Amp)	1.00	1.00	1.00	1.00	1.00	1.00
短时间最大负载 Max.Momentary Torque(Kg.cm)	3.90	7.89	13.00	42.47	76.27	117.00

★备注: 1. 若需要其它规格, 敬请来电联系 2. 如若我司以上规格产生变动, 请恕不再另行通知。

Remark: 1.If any specifications else you required are not listed above, Please contact us 2.The specifications are subject to change without notice.

ZGB80R-80SRZ-1

80S-24VDC/2000RPM

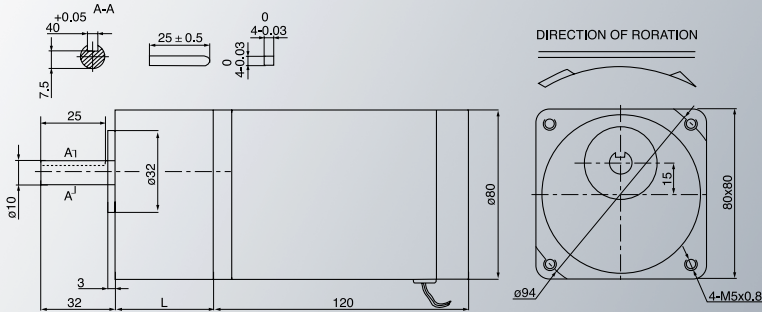

■技术参数 Technical Data

电压 Voltage(VDC)	24V	24V	24V	24V	24V
马达型号 Motor Model	20-80S	20-80S	20-80S	20-80S	20-80S
减速比 Reduction Ratio	1/4.6	1/9.1	1/18	1/23	1/50
齿轮箱长度 Gearbox Length(mm)	32.00	32.00	32.00	44.00	44.00
空载转速 No-Load Speed(Rpm)	434.78	219.78	111.11	86.96	40.00
额定转速 Rated Speed(Rpm)	330.43	167.03	84.44	66.09	30.40
额定力矩 Rated Torque(Kg.cm)	6.70	13.25	26.22	33.50	72.83
额定电流 Rated Current(Amp)	2.20	2.20	2.20	2.20	2.20
短时间最大负载 Max.Momentary Torque(Kg.cm)	8.38	16.57	32.77	41.88	91.03

ZGB90R-80SRZ-1

80S-1-24VDC/2000RPM

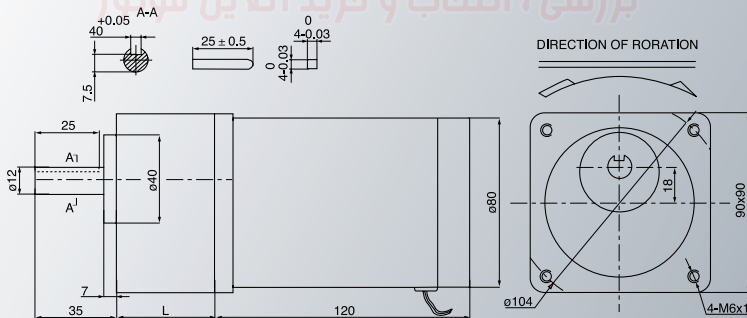

■技术参数 Technical Data

电压 Voltage(VDC)	24V	24V	24V	24V	24V	24V
马达型号 Motor Model	20-80S1	20-80S1	20-80S1	20-80S1	20-80S1	20-80S1
减速比 Reduction Ratio	1/4.7	1/7	1/15	1/20	1/46	1/70
齿轮箱长度 Gearbox Length(mm)	40.00	40.00	40.00	55.00	55.00	55.00
空载转速 No-Load Speed(Rpm)	425.53	285.71	133.33	100.00	43.48	28.57
额定转速 Rated Speed(Rpm)	323.40	217.14	101.33	76.00	33.04	21.71
额定力矩 Rated Torque(Kg.cm)	5.03	7.49	16.05	21.40	49.23	74.91
额定电流 Rated Current(Amp)	1.90	1.90	1.90	1.90	1.90	1.90
短时间最大负载 Max.Momentary Torque(Kg.cm)	6.29	9.36	20.07	26.76	61.54	93.64

★备注: 1. 若需要其它规格, 敬请来电联系 2. 如若我司以上规格产生变动, 请恕不再另行通知。

Remark: 1. If any specifications else you required are not listed above, Please contact us 2. The specifications are subject to change without notice.

ZGB114FO

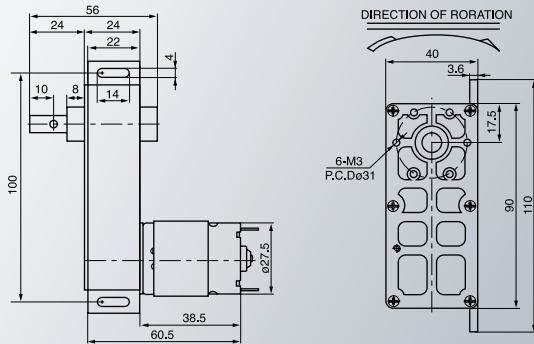

■技术参数 Technical Data

电压 Voltage(VDC)	12V	12V	24V	24V
马达型号 Motor Model	500	500	1000	1000
减速比 Reduction Ratio	1/203	1/283	1/203	1/283
齿轮箱长度 Gearbox Length(mm)	24	24	24	24
空载转速 No-Load Speed(Rpm)	25	18	49	35
额定转速 Rated Speed(Rpm)	19	13	37	27
额定力矩 Rated Torque(Kg.cm)	6.70	9.34	9.64	13.44
额定电流 Rated Current(Amp)	0.45	0.45	0.68	0.68
短时间最大负载 Max.Momentary Torque(Kg.cm)	10.05	14.01	14.46	20.16

ZGB114FH

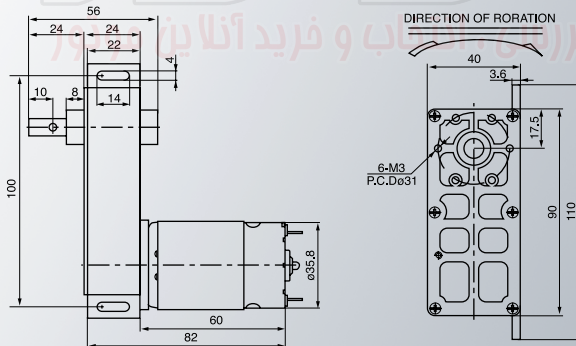

■技术参数 Technical Data

电压 Voltage(VDC)	12V	12V	24V	24V
马达型号 Motor Model	53H	53H	53H	53H
减速比 Reduction Ratio	1/203	1/283	1/203	1/203
齿轮箱长度 Gearbox Length(mm)	24	24	24	24
空载转速 No-Load Speed(Rpm)	26	19	26	26
额定转速 Rated Speed(Rpm)	20	14	20	20
额定力矩 Rated Torque(Kg.cm)	28.35	39.52	37.10	37.10
额定电流 Rated Current(Amp)	1.10	1.10	0.85	0.85
短时间最大负载 Max.Momentary Torque(Kg.cm)	35.44	49.40	46.38	46.38

★备注: 1. 若需要其它规格, 敬请来电联系 2. 如若我司以上规格产生变动, 请恕不再另行通知。

Remark: 1.If any specifications else you required are not listed above, Please contact us 2.The specifications are subject to change without notice.

ZGB114FEE

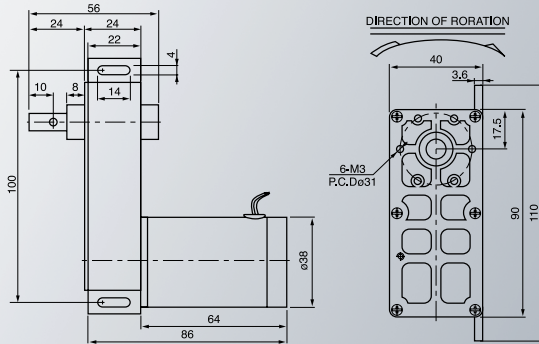

■技术参数 Technical Data

电压 Voltage(VDC)	12V	12V	24V	24V
马达型号 Motor Model	30EE	30EE	35EE	35EE
减速比 Reduction Ratio	1/203	1/283	1/203	1/283
齿轮箱长度 Gearbox Length(mm)	24	24	24	24
空载转速 No-Load Speed(Rpm)	15	11	17	12
额定转速 Rated Speed(Rpm)	20	14	13	9
额定力矩 Rated Torque(Kg.cm)	14.97	21.39	32.29	45.02
额定电流 Rated Current(Amp)	0.78	0.78	0.56	0.56
短时间最大负载 Max.Momentary Torque(Kg.cm)	18.71	26.73	40.36	56.27

ZGB102FEE

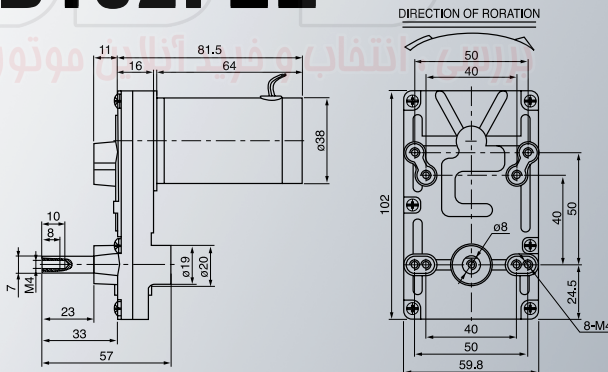

■技术参数 Technical Data

电压 Voltage(VDC)	12V	12V	12V	12V	24V	24V	24V
马达型号 Motor Model	30EE	30EE	30EE	30EE	35EE	35EE	35EE
减速比 Reduction Ratio	1/33	1/77	1/102	1/220	1/33	1/77	1/102
齿轮箱长度 Gearbox Length(mm)	24	24	24	24	24	24	24
空载转速 No-Load Speed(Rpm)	92	39	29	14	108	46	34
额定转速 Rated Speed(Rpm)	70	30	22	10	82	35	26
额定力矩 Rated Torque(Kg.cm)	4.28	10.07	13.43	28.97	9.06	21.33	28.43
额定电流 Rated Current(Amp)	0.78	0.78	0.78	0.78	0.56	0.56	0.56
短时间最大负载 Max.Momentary Torque(Kg.cm)	5.35	12.59	16.79	36.22	11.33	26.66	35.54

★备注: 1.若需要其它规格, 敬请来电联系 2.如若我司以上规格产生变动, 请恕不再另行通知。

Remark: 1.If any specifications else you required are not listed above, Please contact us 2.The specifications are subject to change without notice.

ZGB102FH

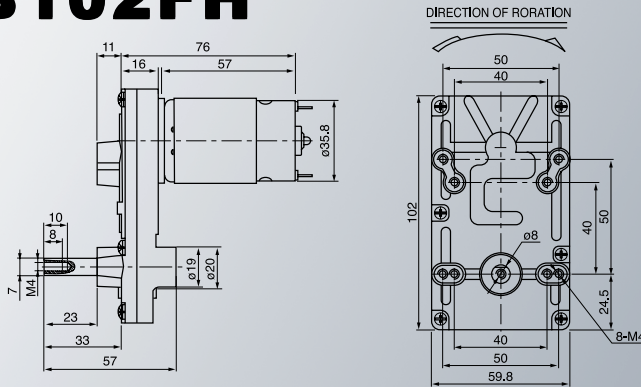

■技术参数 Technical Data

电压 Voltage(VDC)	12V	12V	12V	12V	24V	24V	24V	24V
马达型号 Motor Model	53H	53H	53H	53H	53H	53H	53H	53H
减速比 Reduction Ratio	1/33	1/77	1/102	1/220	1/33	1/77	1/102	1/220
齿轮箱长度 Gearbox Length(mm)	24	24	24	24	24	24	24	24
空载转速 No-Load Speed(Rpm)	163	69	52	24	163	69	52	24
额定转速 Rated Speed(Rpm)	124	53	39	18	124	53	39	18
额定力矩 Rated Torque(Kg.cm)	4.57	10.76	14.34	30.94	5.98	14.08	18.77	40.48
额定电流 Rated Current(Amp)	1.10	1.10	1.0	1.10	0.85	0.85	0.85	0.85
短时间最大负载 Max.Momentary Torque(Kg.cm)	5.71	13.45	17.93	38.67	7.48	17.60	23.46	50.60

ZGB102FGG45S-24VDC/5000RPM

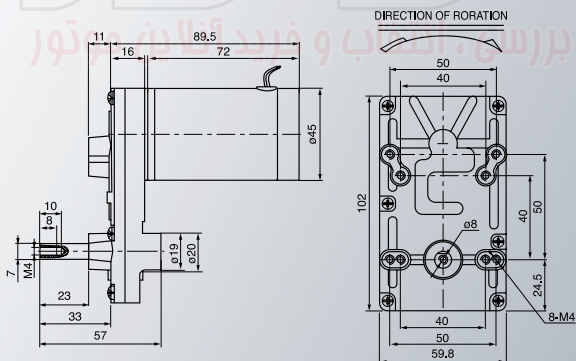

■技术参数 Technical Data

电压 Voltage(VDC)	12V	12V	12V	12V	24V	24V	24V
马达型号 Motor Model	40GG	40GG	40GG	40GG	50GG	50GG	50GG
减速比 Reduction Ratio	1/33	1/77	1/102	1/220	1/33	1/77	1/102
齿轮箱长度 Gearbox Length(mm)	24	24	24	24	24	24	24
空载转速 No-Load Speed(Rpm)	123	52	39	18	154	65	49
额定转速 Rated Speed(Rpm)	94	40	30	14	117	50	37
额定力矩 Rated Torque(Kg.cm)	10.37	24.41	32.55	70.20	10.83	25.49	33.99
额定电流 Rated Current(Amp)	2.00	2.00	2.00	2.00	1.30	1.30	1.30
短时间最大负载 Max.Momentary Torque(Kg.cm)	12.96	30.51	40.68	87.75	13.54	31.87	42.49

★备注: 1. 若需要其它规格, 敬请来电联系 2. 如若我司以上规格产生变动, 请恕不再另行通知。

Remark: 1. If any specifications else you required are not listed above, Please contact us 2. The specifications are subject to change without notice.

ZS-RI

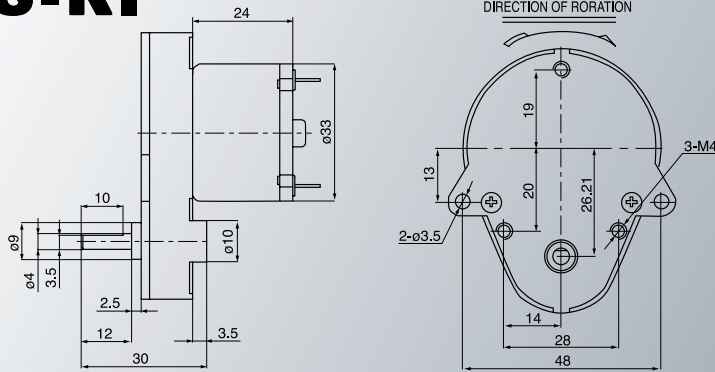

■技术参数 Technical Data

电压 Voltage(VDC)	6V	6V	6V	12V	12V	12V	24V	24V	24V
马达型号 Motor Model	40I	40I	40I	70I	70I	70I	80I	80I	80I
减速比 Reduction Ratio	1/8	1/81	1/179	1/8	1/81	1/179	1/8	1/81	1/179
齿轮箱长度 Gearbox Length(mm)	12	12	12	12	12	12	12	12	12
空载转速 No-Load Speed(Rpm)	482	49	22	843	86	39	964	98	45
额定转速 Rated Speed(Rpm)	366	37	17	641	65	30	733	75	34
额定力矩 Rated Torque(Kg.cm)	0.27	2.64	5.82	0.22	2.15	4.74	0.36	3.53	7.76
额定电流 Rated Current(Amp)	0.62	0.62	0.62	0.33	0.33	0.33	0.30	0.30	0.30
短时间最大负载 Max.Momentary Torque(Kg.cm)	0.34	3.31	7.28	0.28	2.69	5.93	0.45	4.41	9.70

ZS-RE

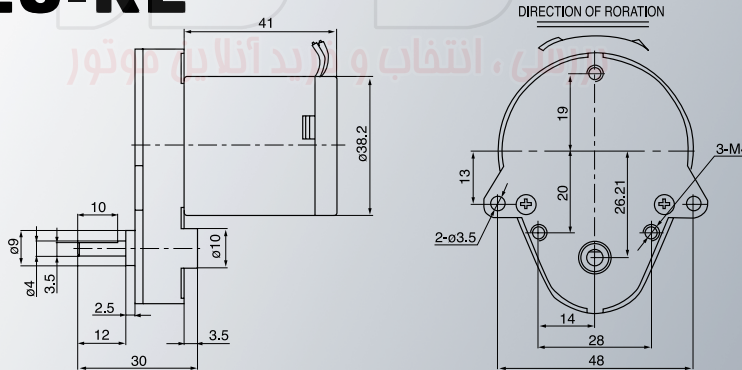

■技术参数 Technical Data

电压 Voltage(VDC)	12V	12V	12V	24V	24V	24V
马达型号 Motor Model	40E	40E	40E	50E	50E	50E
减速比 Reduction Ratio	1/8	1/81	1/179	1/8	1/81	1/179
齿轮箱长度 Gearbox Length(mm)	12	12	12	12	12	12
空载转速 No-Load Speed(Rpm)	482	49	22	602	62	28
额定转速 Rated Speed(Rpm)	366	37	17	458	47	21
额定力矩 Rated Torque(Kg.cm)	1.70	16.65	36.66	1.36	13.32	29.33
额定电流 Rated Current(Amp)	0.86	0.86	0.86	0.42	0.42	0.42
短时间最大负载 Max.Momentary Torque(Kg.cm)	2.13	20.81	45.83	1.70	16.65	36.66

★备注: 1. 若需要其它规格, 敬请来电联系 2. 如若我司以上规格产生变动, 请恕不再另行通知。

Remark: 1.If any specifications else you required are not listed above, Please contact us 2.The specifications are subject to change without notice.

ZS-FI

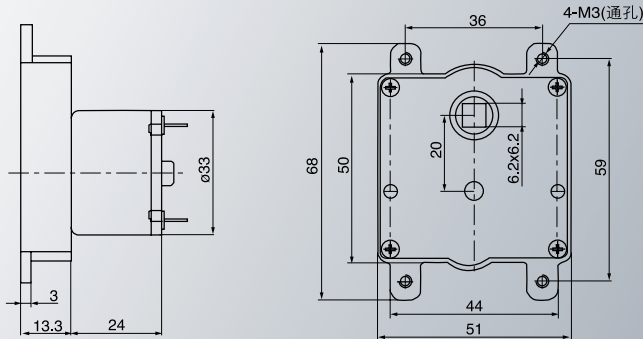

■技术参数 Technical Data

电压 Voltage(VDC)	6V	6V	6V	12	12V	12V	24V	24V	24V
马达型号 Motor Model	40I	40I	40I	70I	70I	70I	80I	80I	80I
减速比 Reduction Ratio	1/88	1/102	1/168	1/88	1/102	1/168	1/88	1/102	1/168
齿轮箱长度 Gearbox Length(mm)	12	12	12	12	12	12	12	12	12
空载转速 No-Load Speed(Rpm)	45	39	24	80	69	42	91	78	48
额定转速 Rated Speed(Rpm)	35	30	18	60	52	32	69	60	36
额定力矩 Rated Torque(Kg.cm)	2.91	3.37	5.56	2.35	2.72	4.49	3.80	4.40	7.25
额定电流 Rated Current(Amp)	0.62	0.62	0.62	0.33	0.33	0.33	0.30	0.30	0.30
短时间最大负载 Max.Momentary Torque(Kg.cm)	3.64	4.22	6.94	2.94	3.40	5.61	4.75	5.51	9.07

ZWL-FP

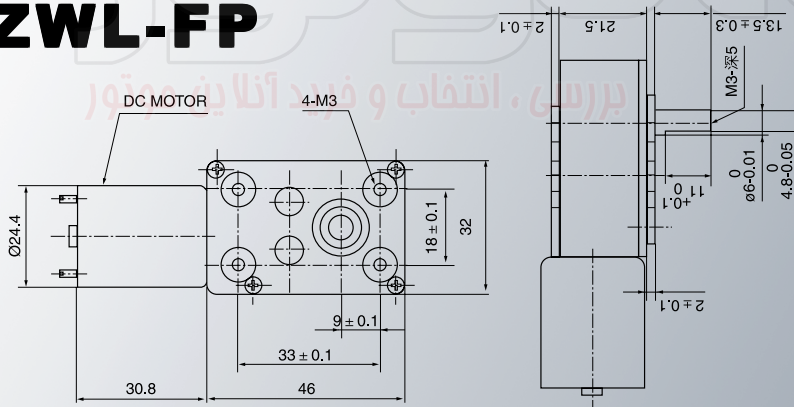

■技术参数 Technical Data

电压 Voltage(VDC)	5V	5V	12V	12V
马达型号 Motor Model	31P	31P	80P	80P
减速比 Reduction Ratio	1650	5300	180	330
空载转速 No-Load Speed(Rpm)	2.0	0.6	35.0	24.0
额定转速 Rated Speed(Rpm)	1.2	0.4	29.0	21.0
额定力矩 Rated Torque(Kg.cm)	12.00	40.00	5.00	6.00
额定电流 Rated Current(Amp)	0.60	0.60	1.10	1.10
短时间最大负载 Max.Momentary Torque(Kg.cm)	15.00	50.00	6.25	7.50

★备注: 1. 若需要其它规格, 敬请来电联系 2. 如若我司以上规格产生变动, 请恕不再另行通知。
Remark: 1. If any specifications else you required are not listed above, Please contact us 2. The specifications are subject to change without notice.

0.5K(370)

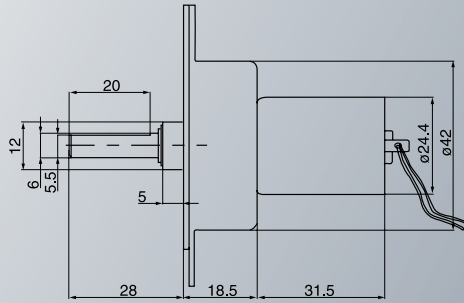
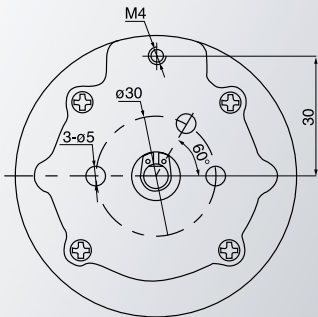

■技术参数 Technical Data

电压 Voltage VDC	空载转速 No-load Speed Rpm	空载电流 No-load Current Amp	额定转速 Sated Speed Rpm	额定电流 Sated Current Amp	额定转矩 Rated Torque G.cm
12V	25	0.028	18	0.098	2.33

1K

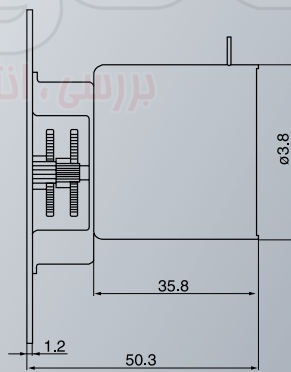
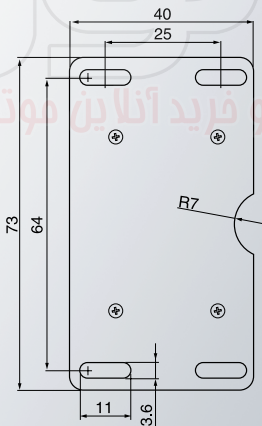

■技术参数 Technical Data

电压 Voltage VDC	空载转速 No-load Speed Rpm	空载电流 No-load Current Amp	额定转速 Sated Speed Rpm	额定电流 Sated Current Amp	额定转矩 Rated Torque G.cm
12V	21	0.025	16	0.078	1.38

★备注: 1.若需要其它规格, 敬请来电联系 2.如若我司以上规格产生变动, 请恕不再另行通知。
Remark: 1.If any specifications else you required are not listed above, Please contact us 2.The specifications are subject to change without notice.

1KM

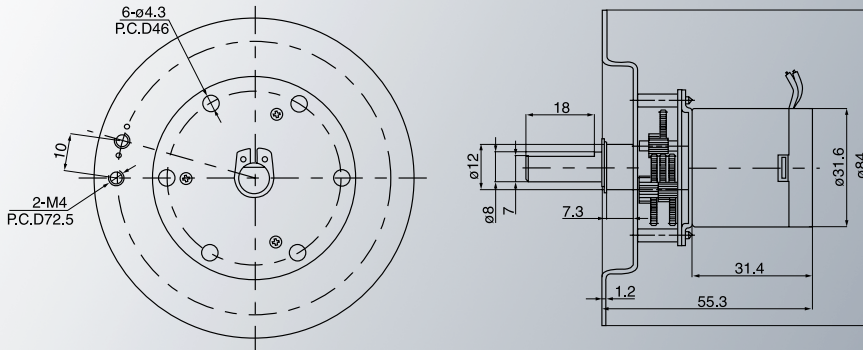

■技术参数 Technical Data

电压 Voltage VDC	空载转速 No-load Speed Rpm	空载电流 No-load Current Amp	额定转速 Sated Speed Rpm	额定电流 Sated Current Amp	额定转矩 Rated Torque G.cm
12V	18	0.04	15	0.117	2.26

2K

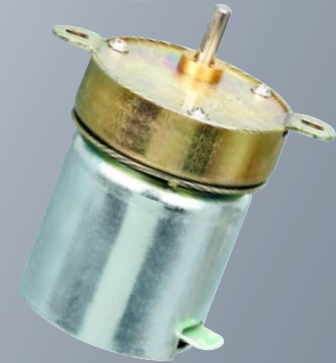
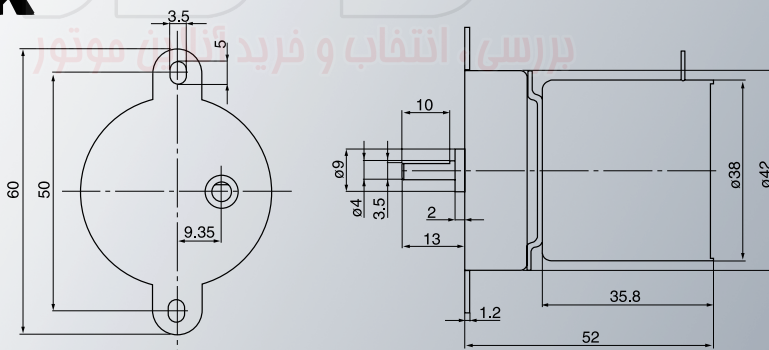

■技术参数 Technical Data

电压 Voltage VDC	空载转速 No-load Speed Rpm	空载电流 No-load Current Amp	额定转速 Sated Speed Rpm	额定电流 Sated Current Amp	额定转矩 Rated Torque G.cm
12V	28	0.03	26	0.04	1.2

★备注: 1. 若需要其它规格, 敬请来电联系 2. 如若我司以上规格产生变动, 请恕不再另行通知。
Remark: 1.If any specifications else you required are not listed above, Please contact us 2.The specifications are subject to change without notice.

2KM

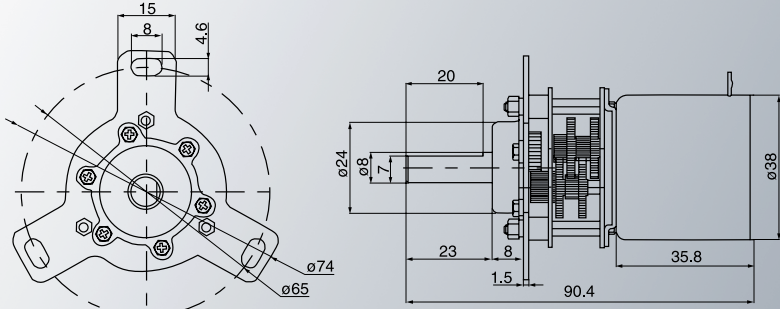

■技术参数 Technical Data

电压 Voltage VDC	空载转速 No-load Speed Rpm	空载电流 No-load Current Amp	额定转速 Sated Speed Rpm	额定电流 Sated Current Amp	额定转矩 Rated Torque G.cm
12V	18	0.02	15	0.06	1.6

3KM

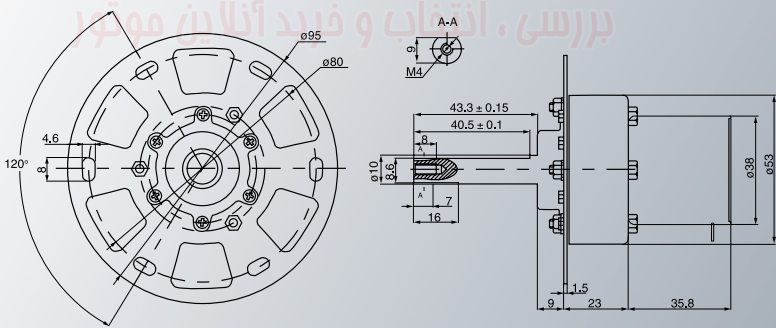

■技术参数 Technical Data

电压 Voltage VDC	空载转速 No-load Speed Rpm	空载电流 No-load Current Amp	额定转速 Sated Speed Rpm	额定电流 Sated Current Amp	额定转矩 Rated Torque G.cm
12V	8	0.04	6.5	0.04	4.8

★备注: 1. 若需要其它规格, 敬请来电联系 2. 如若我司以上规格产生变动, 请恕不再另行通知。
Remark: 1. If any specifications else you required are not listed above, Please contact us 2. The specifications are subject to change without notice.

3KMS

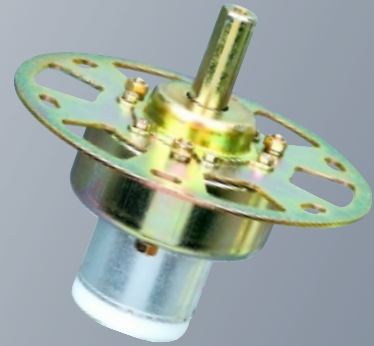
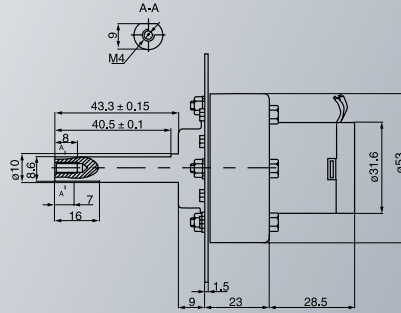
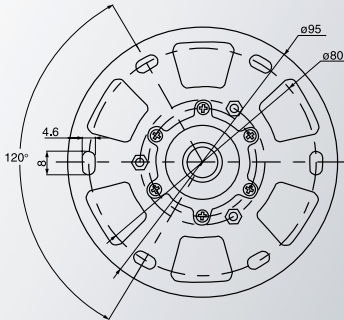

■ 技术参数 Technical Data

电压 Voltage VDC	空载转速 No-load Speed Rpm	空载电流 No-load Current Amp	额定转速 Sated Speed Rpm	额定电流 Sated Current Amp	额定转矩 Rated Torque G.cm
12V	9	0.03	7	0.08	3.15

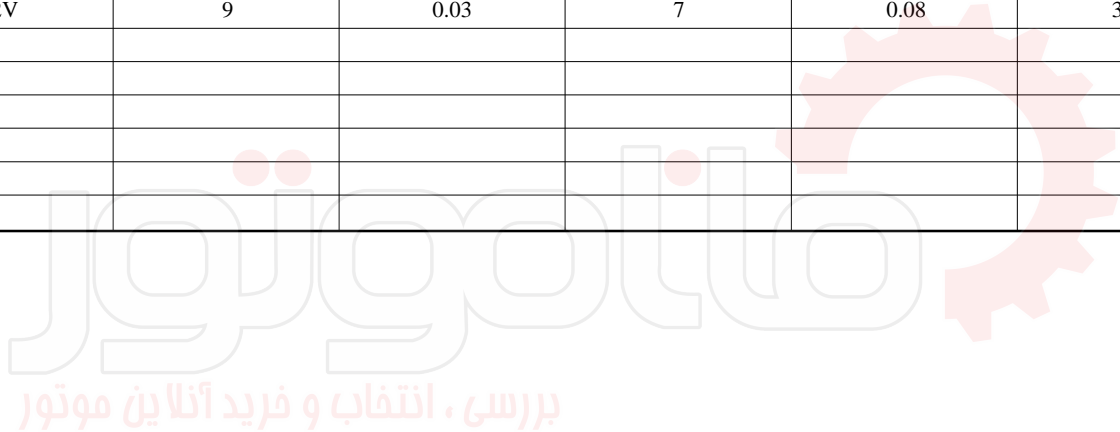

بررسی، انتخاب و فرید آنلاین موتور

★备注: 1.若需要其它规格, 敬请来电联系 2.如若我司以上规格产生变动, 请恕不再另行通知。
Remark: 1.If any specifications else you required are not listed above, Please contact us 2.The specifications are subject to change without notice.

ZYTD-38SRZ

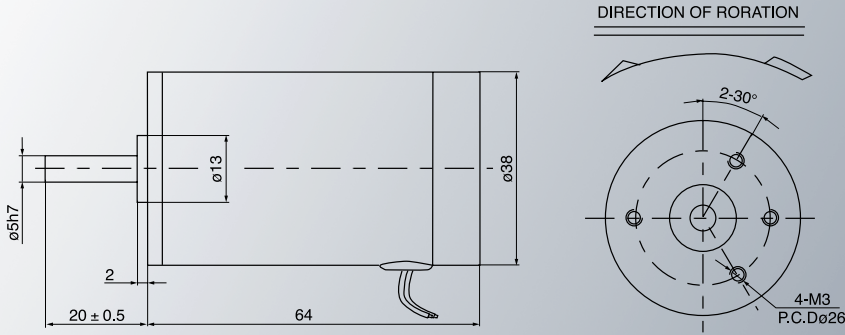

■技术参数 Technical Data

电压 Voltage VDC	空载转速 No-load Speed Rpm	空载电流 No-load Current Amp	额定转速 Sated Speed Rpm	额定电流 Sated Current Amp	额定转矩 Rated Torque G.cm	额定输出功率 Rated Output Watt	堵转力矩 Stall Torque G.cm	堵转电流 Stall Current Amp
12V	2000	0.225	1560	0.43	105	1.7	296	1.2
12V	5000	0.645	3590	1.54	180	6.6	690	3.9

ZYTD-38SRZ-1

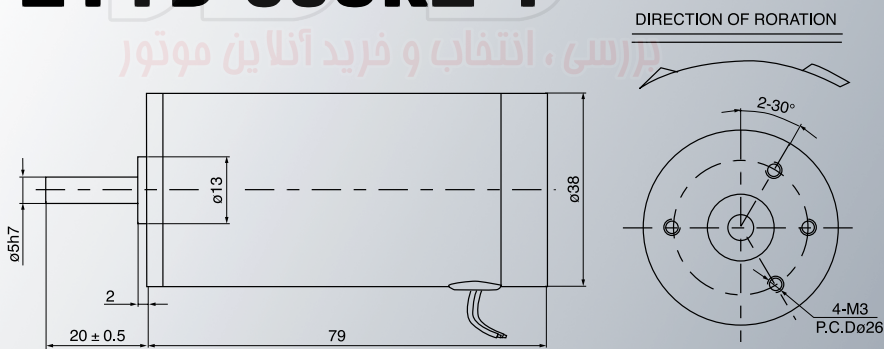

■技术参数 Technical Data

电压 Voltage VDC	空载转速 No-load Speed Rpm	空载电流 No-load Current Amp	额定转速 Sated Speed Rpm	额定电流 Sated Current Amp	额定转矩 Rated Torque G.cm	额定输出功率 Rated Output Watt	堵转力矩 Stall Torque G.cm	堵转电流 Stall Current Amp
12V	3500	0.35	3000	0.81	150	4.6	614	3.3

★备注: 1.若需要其它规格, 敬请来电联系 2.如若我司以上规格产生变动, 请恕不再另行通知。

Remark: 1.If any specifications else you required are not listed above, Please contact us 2.The specifications are subject to change without notice.

ZYTD-45SRZ

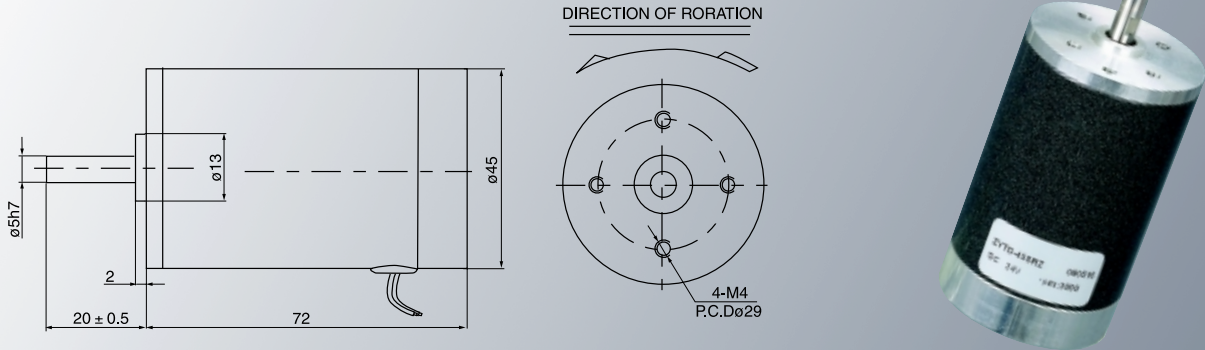

■技术参数 Technical Data

电压 Voltage VDC	空载转速 No-load Speed Rpm	空载电流 No-load Current Amp	额定转速 Sated Speed Rpm	额定电流 Sated Current Amp	额定转矩 Rated Torque G.cm	额定输出功率 Rated Output Watt	堵转力矩 Stall Torque G.cm	堵转电流 Stall Current Amp
12V	2000	0.17	1570	0.53	180	2.9	577	1.7

ZYTD-45SRZ-1

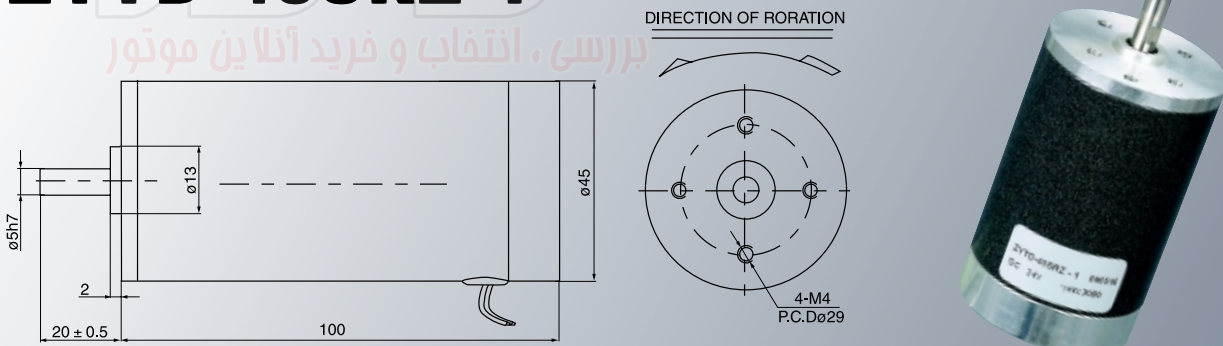

■技术参数 Technical Data

电压 Voltage VDC	空载转速 No-load Speed Rpm	空载电流 No-load Current Amp	额定转速 Sated Speed Rpm	额定电流 Sated Current Amp	额定转矩 Rated Torque G.cm	额定输出功率 Rated Output Watt	堵转力矩 Stall Torque G.cm	堵转电流 Stall Current Amp
12V	3500	0.4	2700	1.00	280	7.8	868	3.1

★备注: 1. 若需要其它规格, 敬请来电联系 2. 如若我司以上规格产生变动, 请恕不再另行通知。
Remark: 1.If any specifications else you required are not listed above, Please contact us 2.The specifications are subject to change without notice.

ZYTD-50SRZ

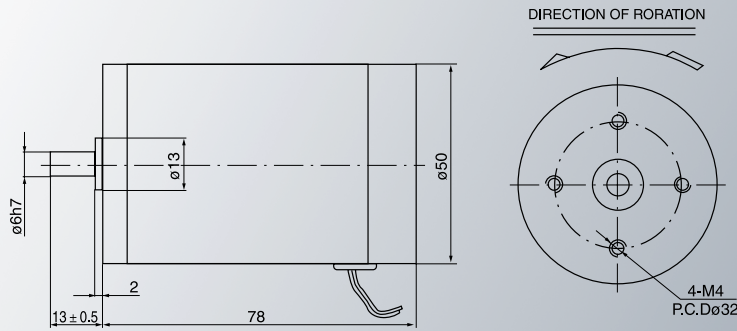

■技术参数 Technical Data

电压 Voltage VDC	空载转速 No-load Speed Rpm	空载电流 No-load Current Amp	额定转速 Sated Speed Rpm	额定电流 Sated Current Amp	额定转矩 Rated Torque G.cm	额定输出功率 Rated Output Watt	堵转力矩 Stall Torque G.cm	堵转电流 Stall Current Amp
12V	2000	0.14	1630	0.70	285	4.8	1220	3
24V	4000	0.2	3600	0.76	285	10.5	2475	6.6

ZYTD-50SRZ-1

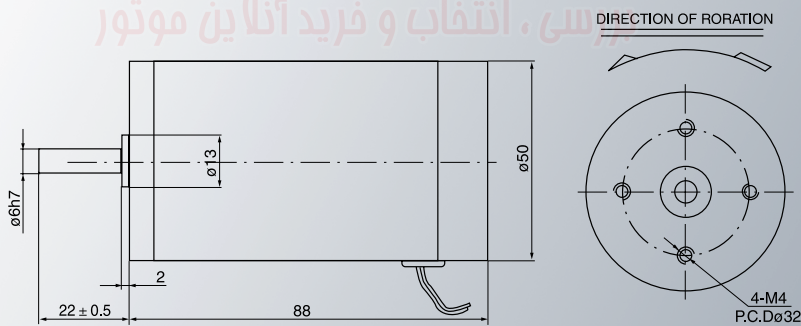

■技术参数 Technical Data

电压 Voltage VDC	空载转速 No-load Speed Rpm	空载电流 No-load Current Amp	额定转速 Sated Speed Rpm	额定电流 Sated Current Amp	额定转矩 Rated Torque G.cm	额定输出功率 Rated Output Watt	堵转力矩 Stall Torque G.cm	堵转电流 Stall Current Amp
24V	2000	0.07	1450	0.70	660	9.8	2074	2.2
24V	4000	0.19	3500	1.50	660	23.7	3608	8.2

★备注: 1. 若需要其它规格, 敬请来电联系 2. 如若我司以上规格产生变动, 请恕不再另行通知。
Remark: 1. If any specifications else you required are not listed above, Please contact us 2. The specifications are subject to change without notice.

ZYTD-60SRZ

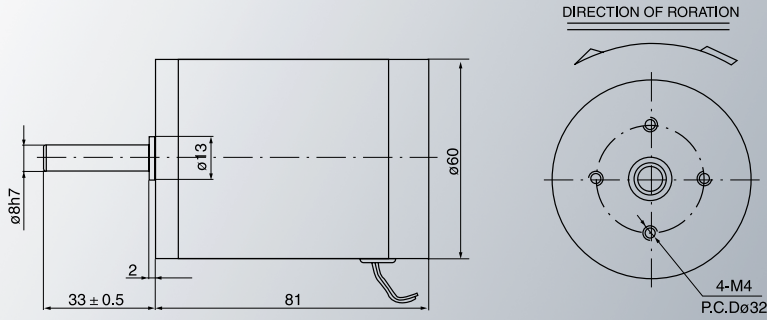

■技术参数 Technical Data

电压 Voltage VDC	空载转速 No-load Speed Rpm	空载电流 No-load Current Amp	额定转速 Sated Speed Rpm	额定电流 Sated Current Amp	额定转矩 Rated Torque G.cm	额定输出功率 Rated Output Watt	堵转力矩 Stall Torque G.cm	堵转电流 Stall Current Amp
24V	2000	0.28	1585	1.14	350	5.7	1382	4.5

ZYTD-60SRZ-1

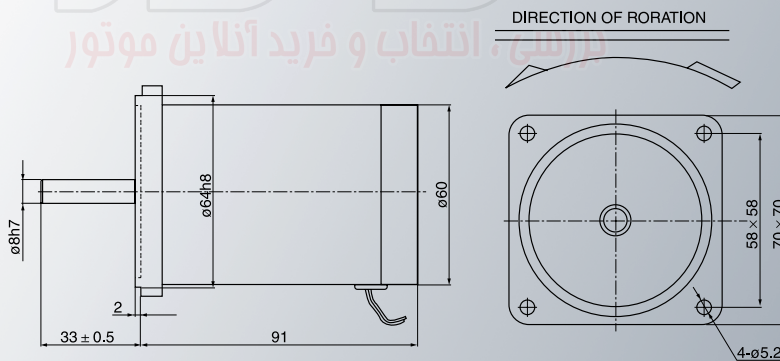

■技术参数 Technical Data

电压 Voltage VDC	空载转速 No-load Speed Rpm	空载电流 No-load Current Amp	额定转速 Sated Speed Rpm	额定电流 Sated Current Amp	额定转矩 Rated Torque G.cm	额定输出功率 Rated Output Watt	堵转力矩 Stall Torque G.cm	堵转电流 Stall Current Amp
12V	2000	0.373	1530	0.86	280	4.4	1730	5.3

★备注: 1. 若需要其它规格, 敬请来电联系 2. 如若我司以上规格产生变动, 请恕不再另行通知。

Remark: 1. If any specifications else you required are not listed above, Please contact us 2. The specifications are subject to change without notice.

ZYTD-60SRZ-2

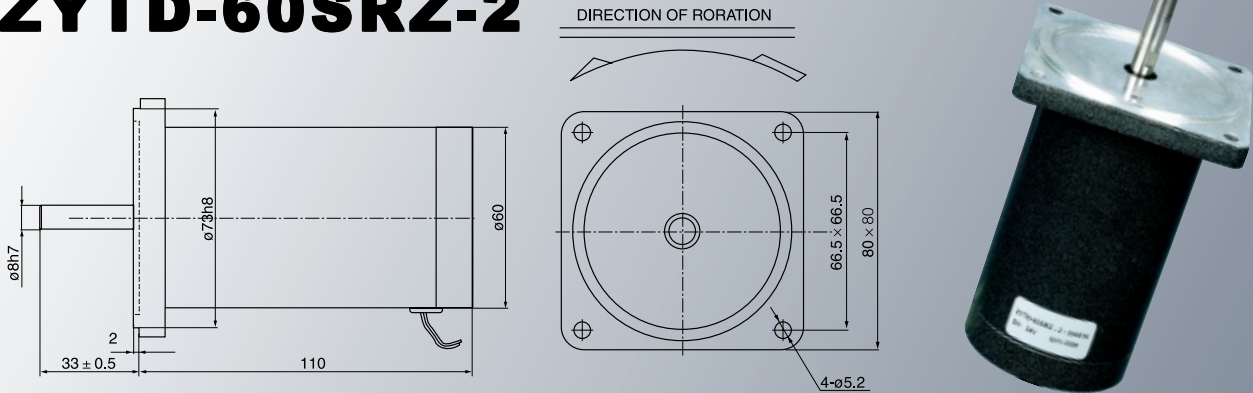

■技术参数 Technical Data

电压 Voltage VDC	空载转速 No-load Speed Rpm	空载电流 No-load Current Amp	额定转速 Sated Speed Rpm	额定电流 Sated Current Amp	额定转矩 Rated Torque G.cm	额定输出功率 Rated Output Watt	堵转力矩 Stall Torque G.cm	堵转电流 Stall Current Amp
24V	4000	0.28	3340	1.52	600	20.6	3434	8.7

ZYTD-80SRZ

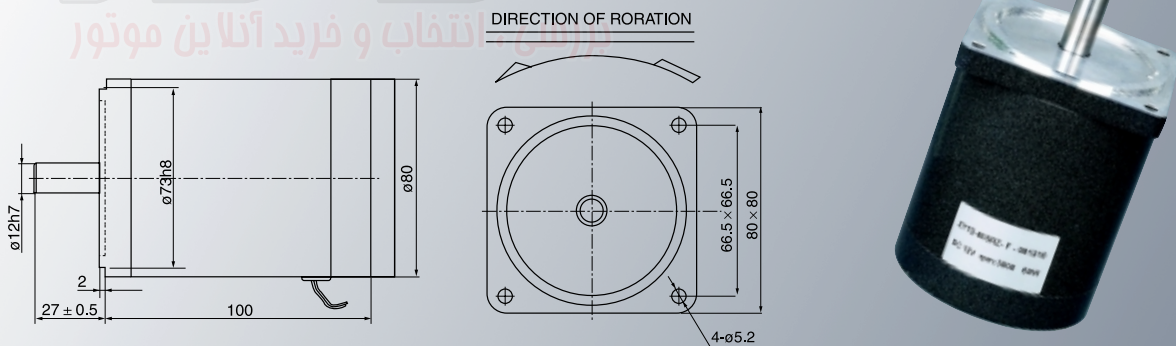

■技术参数 Technical Data

电压 Voltage VDC	空载转速 No-load Speed Rpm	空载电流 No-load Current Amp	额定转速 Sated Speed Rpm	额定电流 Sated Current Amp	额定转矩 Rated Torque G.cm	额定输出功率 Rated Output Watt	堵转力矩 Stall Torque G.cm	堵转电流 Stall Current Amp
12V	3000	1.54	2320	3.30	500	11.9	1077	7.1

★备注: 1.若需要其它规格, 敬请来电联系 2.如若我司以上规格产生变动, 请恕不再另行通知。

Remark: 1.If any specifications else you required are not listed above, Please contact us 2.The specifications are subject to change without notice.

ZYTD-80SRZ-1

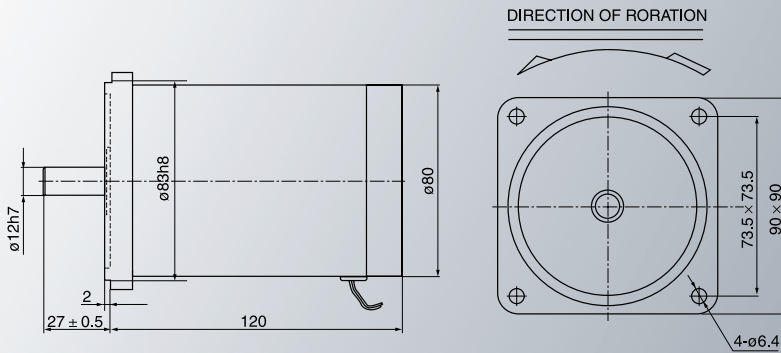

■技术参数 Technical Data

电压 Voltage VDC	空载转速 No-load Speed Rpm	空载电流 No-load Current Amp	额定转速 Sated Speed Rpm	额定电流 Sated Current Amp	额定转矩 Rated Torque G.cm	额定输出功率 Rated Output Watt	堵转力矩 Stall Torque G.cm	堵转电流 Stall Current Amp
24V	2000	0.28	1500	1.54	970	14.9	4472	7.1

ZYTD-80SRZ-2

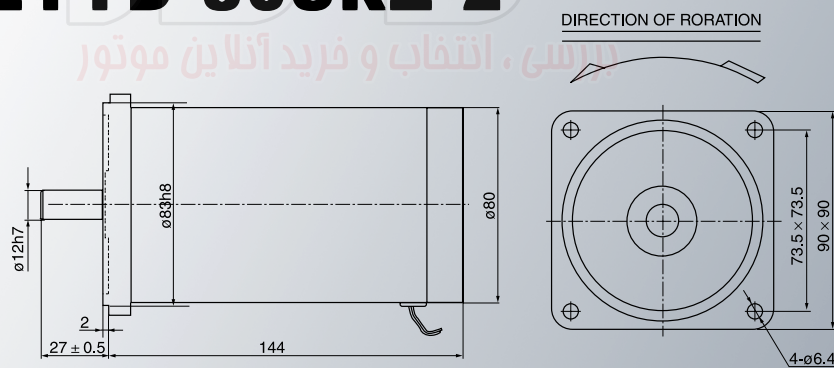

■技术参数 Technical Data

电压 Voltage VDC	空载转速 No-load Speed Rpm	空载电流 No-load Current Amp	额定转速 Sated Speed Rpm	额定电流 Sated Current Amp	额定转矩 Rated Torque G.cm	额定输出功率 Rated Output Watt	堵转力矩 Stall Torque G.cm	堵转电流 Stall Current Amp
12V	3000	1.3	2200	4.30	960	21.7	2858	12.8
24V	5000	1.12	4100	4.00	1120	47.1	4788	17.1

★备注: 1. 若需要其它规格, 敬请来电联系 2. 如若我司以上规格产生变动, 请恕不再另行通知。

Remark: 1. If any specifications else you required are not listed above, Please contact us 2. The specifications are subject to change without notice.

ZY-49

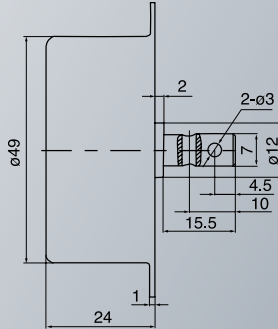
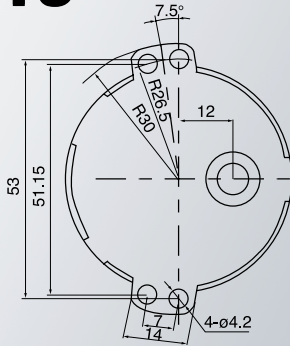

■技术参数 Technical Data

额定电压 Rated Voltage V	220							
额定频率 Rated Frequency Hz	50/60							
输入功率 Input Power W	3/3.5							
输出转速 Speed r/min	1.5	2.5	4	5	8	15	25	35
输出转矩 Torque Kgcm	15	12	7	6.5	6	2.5	1.7	1.2
旋转方向 Rotation Direction	CW/CCW							

50KTYZ

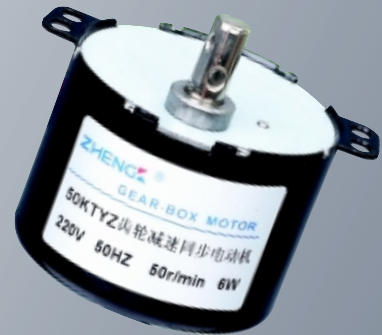
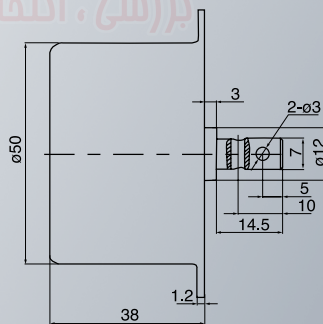
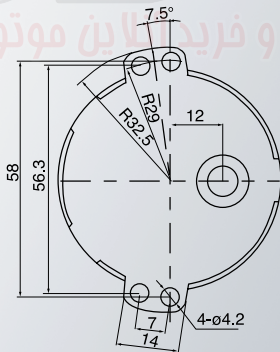

■技术参数 Technical Data

额定电压 Rated Voltage V	220							
额定频率 Rated Frequency Hz	50							
输入功率 Input Power W	6.5							
输出转速 Speed r/min	6	15	20	34	40	60	80	120
输出转矩 Torque Kgcm	7.3	2.9	2.1	1.2	1	0.7	0.5	0.3
旋转方向 Rotation Direction	CW/CCW							

★备注: 1. 若需要其它规格, 敬请来电联系 2. 如若我司以上规格产生变动, 请恕不再另行通知。

Remark: 1. If any specifications else you required are not listed above, Please contact us 2. The specifications are subject to change without notice.

60KTYZ-(偏心)

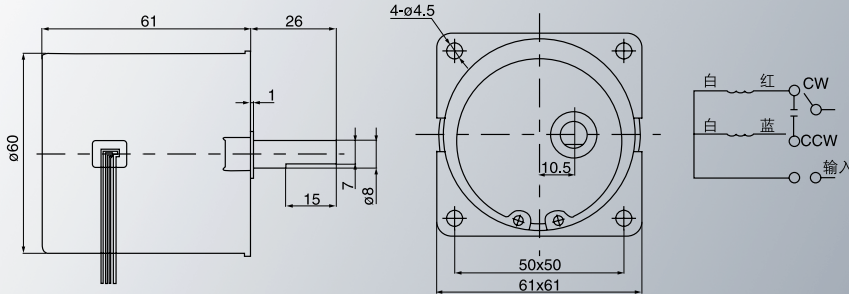

■技术参数 Technical Data

额定电压 Rated Voltage V	220					
额定频率 Rated Frequency Hz	50/60					
输入功率 Input Power W	14					
输出转速 Speed r/min	5	15	20	25	99	
输出转矩 Torque	普通 Commonly	26	10	7.5	6.5	1.8
	Kgcm	较大 Biggish	40	14	10	8.5
旋转方向 Rotation Direction	CW/CCW					

60KTYZ-(中心)

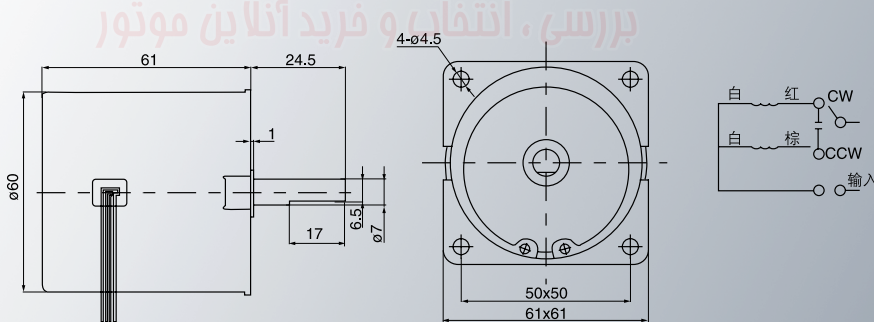

■技术参数 Technical Data

额定电压 Rated Voltage V	220															
额定频率 Rated Frequency Hz	50/60															
输入功率 Input Power W	14															
输出转速 Speed r/min	2.5	3.8	5	7.5	10	12	15	20	25	30	40	50	60	80	110	
输出转矩 Torque	普通 Commonly	45	32	26	20	15	13.5	10	7.5	6.5	5	4	3	2.5	2	1.4
	Kgcm	较大 Biggish	60	50	40	25	20	18	14	10	8.5	7.5	6	4	3.5	2.5
旋转方向 Rotation Direction	CW/CCW															

★备注: 1. 若需要其它规格, 敬请来电联系 2. 如若我司以上规格产生变动, 请恕不再另行通知。
Remark: 1. If any specifications else you required are not listed above, Please contact us 2. The specifications are subject to change without notice.

2RK6W 2RK6W-T



■ 马达特性表 Specifications of motor

马达型号 Motor Model No.		出力 Force W	周波数 Peripheral Wave No Hz	电压 Voltage V	电流 Current A	起动转矩 Start Turning Moment gcm	定格 Rating		起动电容 Start condenser	
可逆马达 Rerersible Motor	圆柱出力轴 Cylindrical Output Shaft						转矩 Turning Moment gcm	回转数 Revolving No rpm	容量 Capacity μF	耐电压 Resistance Voltage V
		2RK6A-A	6	50	110	0.24	600	487	1200	3
60				110	0.22	500	400	1450	2.5	
2RK6A-C		6	50	220	0.12	600	487	1200	0.8	500
			60	220	0.11	500	400	1450	0.7	

■ 外型尺寸 External dimension

马达 MOTOR 圆柱出力轴

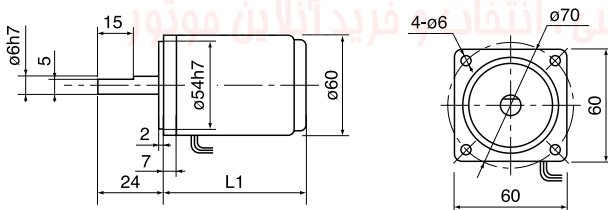

齿轮减速器: GEAR HEAD

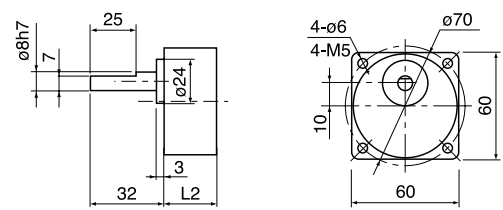

齿轮减速马达: GEARMOTOR

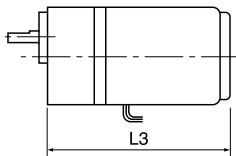

型号 Type	减速比 Reduction ratio	L1 mm	L2 mm	L3 mm
21K(RK)6A(GN)	1:3~1:20	74	33	107
	1:25~1:180	74	42	116

■ 扭距表 Gear Head-Torque Table(Kg-cm)

同步转速 r/min		500	300	200	150	120	100	75	60	50	30	20	15	10	7.5	6	5	3
允许负载 Permissible load	6W kg·cm	1.0	1.6	2.5	3.3	4.1	5	6.6	8.1	9.7	16	23	25	25	25	25	25	25

★备注: 1. 若需要其它规格, 敬请来电联系 2. 如若我司以上规格产生变动, 请恕不再另行通知。
Remark: 1. If any specifications else you required are not listed above, Please contact us 2. The specifications are subject to change without notice.

3RK15W 3RK15W-T



■马达特性表 Specifications of motor

马达型号 Motor Model No.		出力 Force W	周波数 Peripheral Wave No Hz	电压 Voltage V	电流 Current A	起动转矩 Start Turning Moment gcm	定格 Rating		起动电容 Start condenser	
可逆马达 Rerversible Motor	圆柱出力轴 Cylindrical Output Shaft						转矩 Turning Moment gcm	回转数 Revolving No rpm	容量 Capacity μ F	耐电压 Resistance Voltage V
		3RK15A-A	15	50	110	0.40	1350	1200	1200	6
60				110	0.36	1050	9350	1500	5	
3RK15A-C		15	50	220	0.20	1350	1200	1200	1.5	500
			60	220	0.18	1050	9350	1500	1.2	

■外型尺寸 External dimension

马达 MOTOR 圆柱出力轴

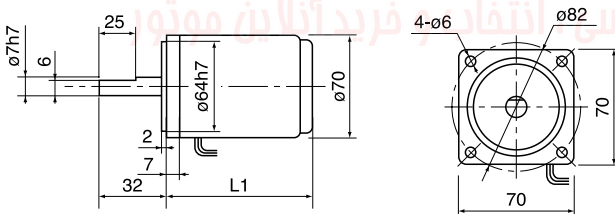

齿轮减速器: GEAR HEAD

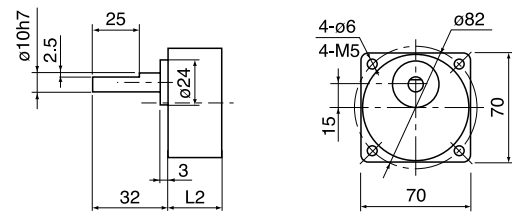

齿轮减速马达: GEARMOTOR

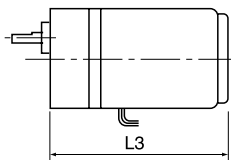

型号 Type	减速比 Reduction ratio	L1 mm	L2 mm	L3 mm
31K(RK)20A(GN)	1:3~1:20	80	32	112
	1:25~1:180	80	42	122

■扭距表 Gear Head-Torque Table(Kg-cm)

同步转速 r/min			500	300	200	150	120	100	75	60	50	30	20	15	10	7.5	6	5	3
允许负载 Permissible load	15W	kg · cm	2.4	4.0	6.0	8	10	12	16	19	23	39	50	50	50	50	50	50	50

★备注: 1.若需要其它规格, 敬请来电联系 2.如若我司以上规格产生变动, 请恕不再另行通知。

Remark: 1.If any specifications else you required are not listed above, Please contact us 2.The specifications are subject to change without notice.

4RK25W 4RK25W-T



■ 马达特性表 Specifications of motor

马达型号 Motor Model No.		出力 Force W	周波数 Peripheral Wave No Hz	电压 Voltage V	电流 Current A	起动转矩 Start Turning Moment gcm	定格 Rating			起动电容 Start condenser	
可逆马达 Rerersible Motor	圆柱出力轴 Cylindrical Output Shaft						转矩 Turning Moment gcm	回转数 Revolving No rpm	容量 Capacity μF	耐电压 Resistance Voltage V	
	4RK25A-A	25	50	110	0.60	1950	1950	1250	8	250	
			60	110	0.55	1650	1620	1500	7		
	4RK25A-C	25	50	220	0.30	1950	1950	1250	2.0	500	
60			220	0.27	1650	1620	1500	1.8			

■ 外型尺寸 External dimension

马达 MOTOR 圆柱出力轴

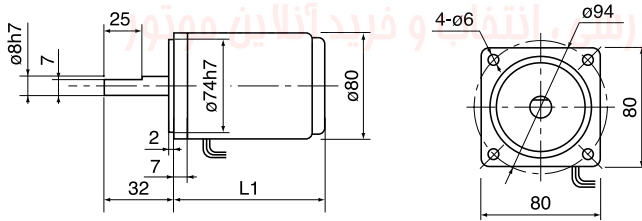

齿轮减速器: GEAR HEAD

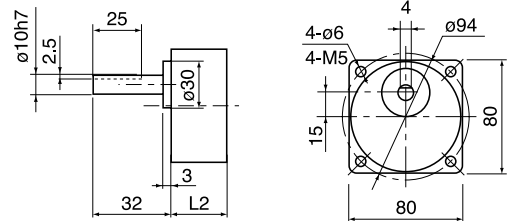

齿轮减速马达: GEARMOTOR

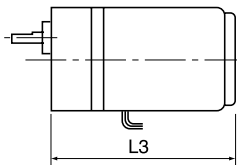

型号 Type	减速比 Reduction ratio	L1 mm	L2 mm	L3 mm
41K(RK)25A(GN)	1:3~1:20	86	32	119
	1:25~1:180	86	44	130

■ 扭距表 Gear Head-Torque Table(Kg-cm)

同步转速 r/min		500	300	200	150	120	100	75	60	50	30	20	15	10	7.5	6	5	3
允许负载 Permissible load	25W kg·cm	4	6.7	10	13.3	16	20	26.7	32	39	65	80	80	80	80	80	80	80

★备注: 1.若需要其它规格, 敬请来电联系 2.如若我司以上规格产生变动, 请恕不再另行通知。

Remark: 1.If any specifications else you required are not listed above, Please contact us 2.The specifications are subject to change without notice.

5RK40W
5RK40W-T
5RK60W
5RK60W-T



■ 马达特性表 Specifications of motor

马达型号 Motor Model No.	圆柱出力轴 Cylindrical Output Shaft	出力 Force W	周波数 Peripheral Wave No Hz	电压 Voltage V	电流 Current A	起动转矩 Start Turning Moment gcm	定格 Rating		起动电容 Start condenser	
							转矩 Turning Moment gcm	回转数 Revolving No rpm	容量 Capacity μF	耐电压 Resistance Voltage V
可逆马达 Reversible Motor	5RK40A-A	40	50	110	0.90	3000	3000	1300	12	250
			60	110	0.82	2500	2515	1550	10	
	5RK40A-C	40	50	220	0.45	3000	1300	1300	3	500
			60	220	0.41	2500	1550	1550	2.5	
	5RK60A-A	60	50	110	1.10	4500	1300	1300	15	250
			60	110	1.0	3770	1550	1550	14	
5RK60A-C	60	50	220	0.55	4500	1300	1300	4	500	
		60	220	0.50	3770	1550	1550	3.5		

■ 外型尺寸 External dimension

马达 MOTOR 圆柱出力轴

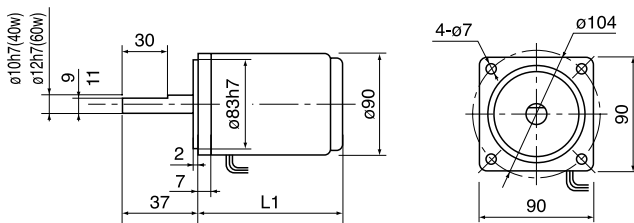

齿轮减速器: GEAR HEAD

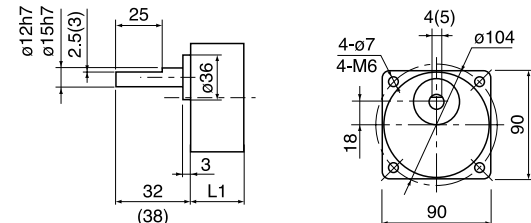

齿轮减速马达: GEARMOTOR

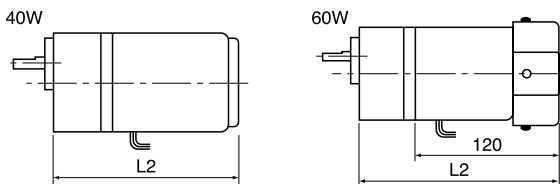

型号 Type	减速比 Reduction ratio	L1 mm	L2 mm
51K(RK)40A(GN)(GU)	1:3~1:20	43	148
51K(RK)60A(GN)(GU)			168
51K(RK)40A(GN)(GU)	1:25~1:180	61	166
51K(RK)60A(GN)(GU)			186

■ 扭距表 Gear Head-Torque Table(Kg-cm)

同步转速 r/min		500	300	200	150	120	100	75	60	50	30	20	15	10	7.5	6	5	3
允许负载 Permissible load	40W kg·cm	6.7	11	16	21.3	28	33	42	54	65	108	150	150	150	150	150	150	150
	60W kg·cm	10	16	24	32	40	48	64	77	93	150	150	150	150	150	150	150	150

★备注: 1. 若需要其它规格, 敬请来电联系 2. 如若我司以上规格产生变动, 请恕不再另行通知。
Remark: 1.If any specifications else you required are not listed above, Please contact us 2.The specifications are subject to change without notice.

5RK90W 5RK90W-T

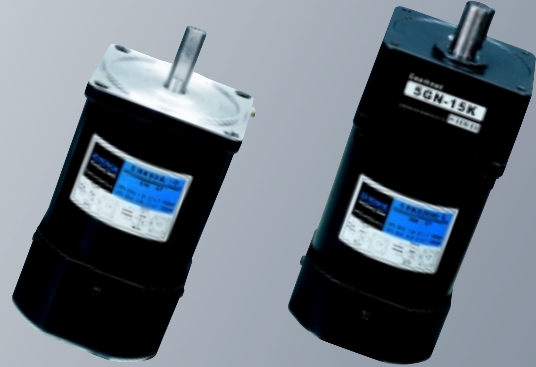

■马达特性表 Specifications of motor

马达型号 Motor Model No.		出力 Force W	周波数 Peripheral Wave No Hz	电压 Voltage V	电流 Current A	起动转矩 Start Turning Moment gcm	定格 Rating			起动电容 Start condenser	
可逆马达 Rerersible Motor	圆柱出力轴 Cylindrical Output Shaft						转矩 Turning Moment gcm	回转数 Revolving No rpm	容量 Capacity μF	耐电压 Resistance Voltage V	
		5RK90A-A	90	50	110	2.0	6400	6750	1300	25	250
60				110	1.80	5400	5650	1550	20		
5RK90A-C		90	50	220	1.0	6400	6750	1300	6.0	500	
			60	220	0.90	5400	5650	1550	5.0		

■外型尺寸 External dimension

马达 MOTOR 圆柱出力轴

齿轮减速器: GEAR HEAD

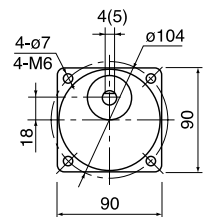
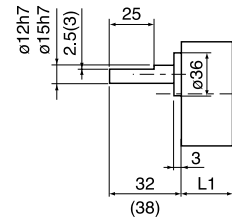
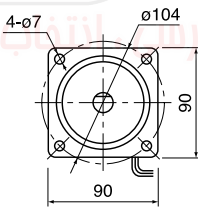
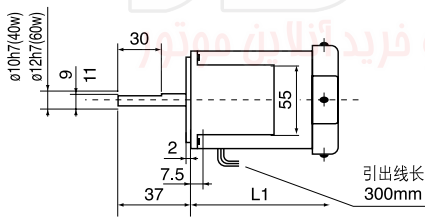

出轴键槽: SHAFT SLOT

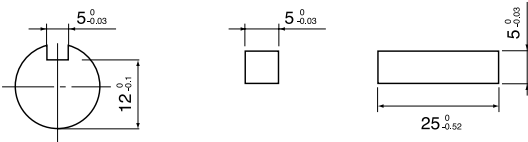

型号 Type	减速比 Reduction ratio	L1 mm	L2 mm
5IK(RK)90A(GN)(GU)	1:3-1:20	140	43
5IK(RK)90A(GN)(GU)	1:25-1:180	140	65
5IK(RK)120A(GN)(GU)	1:3-1:20	140	43
5IK(RK)120A(GN)(GU)	1:25-1:180	140	65

■扭距表 Gear Head-Torque Table(Kg-cm)

同步转速 r/min		500	300	200	150	120	100	75	60	50	30	20	15	10	7.5	6	5	3
允许负载 Permissible load	90W kg·cm	14	23	35	46	58	69	92	110	133	200	200	200	200	200	200	200	200

★备注: 1.若需要其它规格, 敬请来电联系 2.如若我司以上规格产生变动, 请恕不再另行通知。

Remark: 1.If any specifications else you required are not listed above, Please contact us 2.The specifications are subject to change without notice.

6RK120W
6RK120W-T
6RK140W
6RK140W-T



■ 马达特性表 Specifications of motor

马达型号 Motor Model No.		出力 Force W	周波数 Peripheral Wave No Hz	电压 Voltage V	电流 Current A	起动转矩 Start Turning Moment gcm	定格 Rating		起动电容 Start condenser	
可逆马达 Rerversible Motor	圆柱出力轴 Cylindrical Output Shaft						转矩 Turning Moment gcm	回转数 Revolving No rpm	容量 Capacity μ F	耐电压 Resistance Voltage V
		6RK120A-A	120	50	110	2.40	9500	9000	1300	35
60				110	2.20	7900	7550	1550	30	
6RK120A-C		120	50	220	1.20	9500	9000	1300	8	500
			60	220	1.10	7900	7550	1550	7	
6RK140A-A		140	50	110	2.80	11000	10500	1300	40	250
			60	110	2.60	9300	8800	1550	30	
6RK140A-C	140	50	220	1.40	11000	10500	1300	10	500	
		60	220	1.30	9300	8800	1550	8		

■ 外型尺寸 External dimension

马达 MOTOR 圆柱出力轴

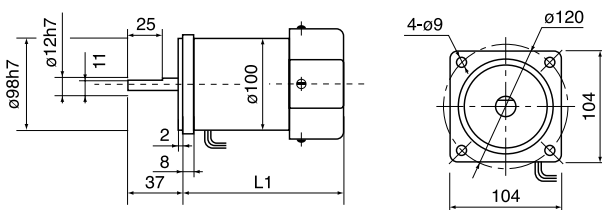

齿轮减速器: GEAR HEAD

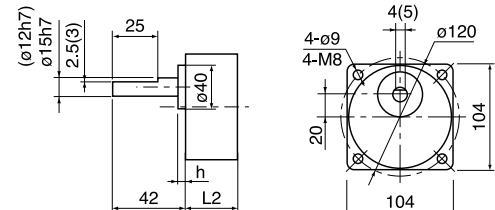

齿轮减速马达: GEARMOTOR

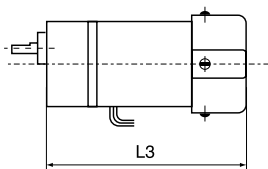

型号 Type	减速比 Reduction ratio	L1 mm	L2 mm	L3 mm	h mm
6IK(RK)120A(GN)(GU)	1:3~1:20	141	42	183	6
	1.25~1:50	141	50	191	
	1:60~1:300	141	62	206	10
6IK(RK)140A(GN)(GU)	1:3~1:20	163	42	205	6
	1.25~1:50	163	50	213	
	1:60~1:300	163	65	228	10

■ 扭距表 Gear Head-Torque Table(Kg-cm)

同步转速 r/min		500	300	200	150	120	100	75	60	50	30	20	15	10	7.5	6	5	3
允许负载 Permissible load	120W kg·cm	18.7	30.7	46	61	77	92	123	147	177	295	450	450	450	450	450	450	450
	140W kg·cm	22	36	53.5	71	90	107	143.5	171.5	206	340	450	450	450	450	450	450	450

★备注: 1. 若需要其它规格, 敬请来电联系 2. 如若我司以上规格产生变动, 请恕不再另行通知。
Remark: 1. If any specifications else you required are not listed above, Please contact us 2. The specifications are subject to change without notice.

6RK180W
6RK180W-T
6RK200W
6RK200W-T



■ 马达特性表 Specifications of motor

马达型号 Motor Model No.		出力 Force W	周波数 Peripheral Wave No Hz	电压 Voltage V	电流 Current A	起动转矩 Start Turning Moment gcm	定格 Rating		起动电容 Start condenser	
可逆马达 Rerversible Motor	圆柱出力轴 Cylindrical Output Shaft						转矩 Turning Moment gcm	回转数 Revolving No rpm	容量 Capacity μF	耐电压 Resistance Voltage V
	可逆马达 Rerversible Motor	6RK180A-A	180	50	110	3.60	13100	13500	1300	50
60				110	3.30	11700	11320	1550	40	
6RK180A-C		180	50	220	1.80	13100	13500	1300	12	500
			60	220	1.65	11700	11320	1550	10	
6RK200A-A		200	50	110	3.80	140550	15000	1300	60	250
			60	110	3.50	11750	12580	1550	50	
6RK200A-C	200	50	220	1.90	14050	15000	1300	14	500	
		60	220	1.75	11750	12580	1550	12		

■ 外型尺寸 External dimension

马达 MOTOR 圆柱出力轴

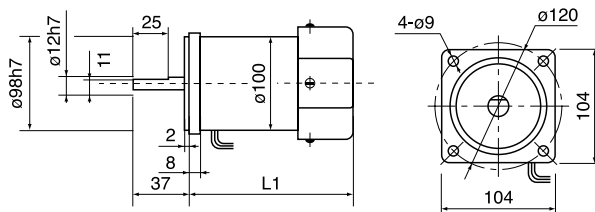

齿轮减速器: GEAR HEAD

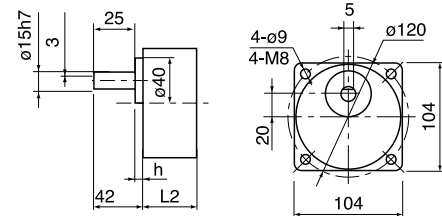

齿轮减速马达: GEARMOTOR

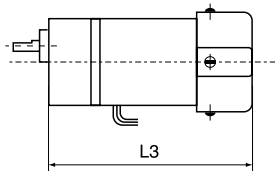

型号 Type	减速比 Reduction ratio	L1 mm	L2 mm	L3 mm	h mm
6IK(RK)180A(GN)(GU)	1:3~1:20	163	42	205	6
	1.25~1:50	163	50	213	
	1:60~1:300	163	62	228	10
6IK(RK)200A(GN)(GU)	1:3~1:20	163	42	205	6
	1.25~1:50	163	50	213	
	1:60~1:300	163	65	228	10

■ 扭距表 Gear Head-Torque Table(Kg-cm)

同步转速 r/min		500	300	200	150	120	100	75	60	50	30	20	15	10	7.5	6	5	3	
允许负载 Permissible load	180W kg·cm	28	46	70	93	116	138	184	220	266	450	450	450	450	450	450	450	450	450
	200W kg·cm	31	51	78	103	129	153	205	245	296	450	450	450	450	450	450	450	450	450

★备注: 1.若需要其它规格, 敬请来电联系 2.如若我司以上规格产生变动, 请恕不再另行通知。
Remark: 1.If any specifications else you required are not listed above, Please contact us 2.The specifications are subject to change without notice.



ZHENGKE

温州市正科电机有限公司

WENZHOU ZHENGKE ELECTROMOTOR CO.,LTD

地址 Add: 温州北白象坂塘工业园区 Bantang Industrial Zone, Beibaixiang, Wenzhou

内贸

总机(General tel): 86-577-62890088

电话(Tel): 86-577-62889922

传真(Fax): 86-577-62890077

邮编(P.c): 325603

Http://www.zhengke.cn

E-mail: zk@zhengke.cn

Exporting Dept

Tel: 86-577-62890918 62890718

Fax: 86-577-62890077

P.c: 325603

Http://www.zhengke-motor.com

E-mail: sales@zhengke.cn

©本产品样本内容若有改动恕不通知 The contents are subject to change without notice